



LEHMAN COLLEGE  
DEPARTMENT OF  
**Physics & Astronomy**

GENERAL PHYSICS I  
**LABORATORY MANUAL**

PHY 166/8  
SPRING 2022

# TABLE OF CONTENTS

1. Lab Policy .....	2
2. Rules of Conduct .....	3
3. Writing a Lab Report .....	4
4. Introduction: Measurement & Uncertainty.....	6
5. Introduction: Units & Conversions.....	14
6. Experiment 1: Acceleration due to free-fall.....	15
7. Experiment 2: Static Equilibrium.....	20
8. Experiment 3: Newton's Second Law.....	24
9. Experiment 4: Conservation in Collisions .....	29
10. Experiment 5: Rotational Equilibrium.....	37
11. Experiment 6: Archimedes' Principle.....	42
12. Experiment 7: Simple Harmonic Motion.....	45

## Laboratory Policy

- Students must attend the lab section they have registered for.
- Labs start on time. Latecomers will not be allowed in the room once the experiment has started.
- To get credit for a lab you must complete and turn in a lab report on time. If you attend a lab session but fail to hand in a report on time you will receive a grade of zero for that lab.
- Lab reports are to be typed using a word processor and are to be handed in electronically on the Blackboard page for your section.
- Lab reports will be checked for plagiarism (copied work) by SafeAssign, a program detects any similarities between your report and entries from a database of books, articles, websites, & other lab reports.
- Labs can be made up only within one week of your scheduled lab session, and only if there is a valid, documented reason for missing your lab. Permission for makeup labs must be obtained in advance from your lab instructor.

## Rules of Conduct & Safety in Labs

- Students are not permitted in the laboratory without an instructor. They shall wait in the corridors until their instructor lets them in at the right time.
- Students should keep all personal belongings off the table and out of the walkways. This will benefit the students have a clear work area, and prevent anyone around them from tripping/falling.
- Students should report any accidents (breakage, malfunction, spills, etc), any unsafe conditions (sparks, unusual odors), or any personal injuries (spill, breakage, etc.) to the instructor without any delay.
- Students should report any damaged equipment they come across (eg. frayed cords, exposed wires, cracked/dirty optics, etc) to the instructor immediately.
- Any chemicals in the laboratory are to be considered dangerous and students are advised to handle them carefully, and let their instructor guide them on how to dispose a chemical being used during an experiment.
- Students should never short the power output terminals (ie. connect the positive & negative directly using a wire).
- Students should make sure that the current is turned off before any adjustments are made in the circuit.
- Students should pull after grasping the plug instead of the cord when disconnecting any electronic devices connected to any outlets.
- Students should handle optics very carefully, and take special care when using an eyepiece to avoid personal injuries.
- Students should not toss any tools, supplies, or other equipment to anyone. They should carefully hand said item to the recipient.
- Students should not climb to stand on any lab furniture.
- Students should conduct themselves in a professional & responsible manner at all times in the laboratory.
- Students should not eat or drink in labs. They can ask their instructor to be excused, and then step outside if they feel the need to do so.
- Students should clean up their respective work areas before leaving a lab.
- Students will benefit from staying alert at all times during the lab!

~ Happy Experimenting! ~

# Writing a laboratory report

## OBJECTIVES

---

The main way to communicate scientific information today is through articles and reports in scientific journals. Traditionally these were distributed in print, but can now be read in digital format as well, as shown in table 1.

Resource	Topics	URL
arXiv	Physics, Mathematics, Computer Science	<a href="http://arxiv.org/">http://arxiv.org/</a>
NASA Scientific and Technical Information (STI)	Astronomy, Aerospace Engineering	<a href="http://www.sti.nasa.gov/STI-public-homepage.html">www.sti.nasa.gov/STI-public-homepage.html</a>
SOA/NASA Astrophysics Data System	Astronomy, physics	<a href="http://adswww.harvard.edu/">adswww.harvard.edu/</a>

In college physics, you write a laboratory report for each experiment that contains the essential information about the experiment. For scientific information, a consistent format is helpful to the reader (and your lab instructor). Each laboratory report you turn in contains a subset of the sections found in a professional scientific publication for experimental topics, as shown in table 2.

**Table 1. A comparison of the sections of a laboratory report and a professional scientific publication**

Laboratory Report	Professional Publication
1. Name, date and title of the experiment	1. Cover page: name, date, and title
2. Abstract	2. Abstract
	3. Introduction
	4. Methods and procedure
3. Data	5. Raw data and graphs
4. Calculations and analysis	6. Calculations and analysis
	7. Results
5. Conclusion	8. Discussion and conclusion

The content to include in each section is detailed below. Your lab instructor requires all five sections to evaluate your work, so be sure to include every section in every report.

A laboratory report must be typed. Photocopies of the manual are not accepted. Your laboratory instructor can tell you whether your laboratory report must be printed or can be delivered in a digital format such as email.

## ABSTRACT

---

Describe in your own words what you did in the experiment and why. Your abstract should include one or two sentences each for Purpose, Methods and Conclusions.

- **Purpose:** What physical principle or law does this experiment test?
- **Methods:** What apparatus did you use? How did you analyze the data?
- **Conclusions:** Do your results support the physical law or principle? You should describe any significant experimental errors or uncertainties.

Note that the abstract should be no more than 5 or 6 sentences long, and should not include too much detail. The goal of the abstract is to sum up the experiment quickly and succinctly.

## DATA

---

The data section includes all the raw data you collected in the laboratory without any calculation or interpretation. At a minimum, include the following information:

- A copy of the data table with all fields and rows filled with measurements.
- Any drawings or sketches you were required to make in the laboratory. You must deliver drawings with a printed lab report. You can take a digital photograph of your drawings and import it to a document as needed.

## CALCULATIONS AND ANALYSIS

---

In the calculations and analysis section, you write out all of your calculations and results as explained in the instructions for the experiment. Be sure to answer all of the questions in the lab manual. Include the following information as instructed:

- The equations you used to make all calculations
- Tables of calculated values
- Graphs of the raw data or calculated values
- Average values, uncertainty, and % uncertainty calculations
- Error and % error calculations

## CONCLUSION

---

In the conclusion section, interpret the results you obtained by analyzing the data. Include the following information:

- Do your data and calculations support the physical principle or law being tested?
- What are the important sources of experimental error and uncertainty?
- Are there ways you could have improved your experimental results?
- Also answer any specific questions posed by your lab instructor.

# Introduction: Measurement and uncertainty

No physical measurement is ever completely precise. All measurements are subject to some uncertainty, and the determination of this uncertainty is an essential part of the analysis of the experiment.

Experimental data include three components: 1) the value measured, 2) the uncertainty, and 3) the units. For example a possible result for measuring a length is  $3.6 \pm 0.2 \text{ m}$ . Here 3.6 is the measured value,  $\pm 0.2$  specifies the uncertainty, and  $\text{m}$  gives the units (meters).

## ERRORS AND UNCERTAINTIES

---

The accuracy of any measurement is limited. An *uncertainty* is our best estimate of how accurate a measurement is, while an *error* is the discrepancy between the measured value of some quantity and its true value. Errors in measurements arise from different sources:

- a) A common type of error is a blunder due to carelessness in making a measurement, for example an incorrect reading of an instrument. Of course these kinds of mistakes should be avoided.
- b) Errors also arise from defective or improperly calibrated instruments. These are known as systematic errors. For example, if a balance does not read zero when there is no mass on it, then all of its readings will be in error, and we must either recalibrate it, or be careful to subtract the empty reading from all subsequent measurements.
- c) Even after we have made every effort to eliminate these kinds of error, the accuracy of our measurements is still limited due to so-called statistical uncertainties. These uncertainties reflect unpredictable random variations in the measurement process: variations in the experimental system, in the measuring apparatus, and in our own perception! Since these variations are random, they will tend to cancel out if we average over a set of repeated measurements. To measure a quantity in the laboratory, one should repeat the measurement many times. The average of all the results is the best estimate of the value of the quantity.
- d) Besides the uncertainty introduced in a measurement due to random fluctuations, vibrations, etc., there are also so-called instrumental uncertainties which are due to the limited accuracy of the measuring instruments we use. For example, if we use a meter stick to measure a length, we can, at best, estimate the length to within about half of the smallest division on the stick or 0.5 millimeters. Beyond that we have no knowledge. It is important to realize that this kind of uncertainty persists, even if we obtain identical readings on repeated trials.

## CALCULATING AVERAGES

---

There are several important steps we will follow to help us quantify and control the errors and uncertainties in our laboratory measurements.

Most importantly, in order to minimize the effect of random errors, one should always perform several independent measurements of the same quantity and take an average of all these readings. In taking the average the random fluctuations tend to cancel out. In fact, the larger the number of measurements taken, the more likely it is that random errors will cancel out.

When we have a set of  $n$  measurements  $x_1, x_2, \dots, x_n$  of a quantity  $x$ , our *best estimate* for the value of  $x$  is the average value  $\bar{x}$ , is defined as follows.

$$\text{Average value:} \quad \bar{x} = \frac{x_1 + x_2 + \dots + x_n}{n} \quad (0.1)$$

The average value is also known as the mean value. Note that when making repeated measurements of a quantity, one should pay attention to the consistency of the results. If one of the numbers is substantially different from the others, it is likely that a blunder has been made, and this number should be excluded when analyzing the results.

## REPORTING ERRORS

---

Quite often in these labs one has to compare a value obtained by measurement with a standard or generally accepted value. To quantify this one can compute the *percent error*, defined as follows.

$$\text{Percent error:} \quad \% \text{ Error} = \left| \frac{\text{measured value} - \text{accepted value}}{\text{accepted value}} \right| \times 100 \quad (0.2)$$

Sometimes one has to report an error when the accepted value is zero. You'll encounter this situation in experiment 3. The procedure to follow is described at the end of that experiment.

## CALCULATING UNCERTAINTIES

---

To estimate the uncertainty associated with our best estimate of  $x$ , we begin by examining scatter of the measurements about the mean  $\bar{x}$ . Specifically, we start by determining the absolute value of the deviation of each measurement from the mean:

$$\text{Deviation:} \quad \Delta x_i = |x_i - \bar{x}| \quad (0.3)$$

Next we have to compare the deviation to the systematic or reading uncertainty due to limited accuracy of the instrument used. If this systematic uncertainty  $R$  is bigger than the deviation  $\Delta x_i$ , then the result of our measurements can be written as

$$\bar{x} \pm R \quad (0.4)$$

If, however, the deviation is larger than the systematic or reading error, then we must determine how big the random uncertainty in our measurements is. This is given by the standard deviation, defined as follows.

$$\text{Standard deviation:} \quad \sigma = \sqrt{\frac{(\Delta x_1)^2 + (\Delta x_2)^2 + \dots + (\Delta x_n)^2}{n - 1}} \quad (0.5)$$

The standard deviation has the following meaning: if we were to make one single additional measurement of the quantity  $x$ , there is 68% probability of obtaining a value which lies between  $\bar{x} - \sigma$  and  $\bar{x} + \sigma$ . The uncertainty in the average value  $\bar{x}$  is smaller (that's the whole point of



taking an average!). In fact the uncertainty in  $\bar{x}$  is the standard deviation divided by the square root of the number of measurements:

$$\text{Uncertainty in } \bar{x}: \quad U = \frac{\sigma}{\sqrt{n}} \quad (0.6)$$

Sometimes it is useful to express this as a percent uncertainty, defined as one hundred times the uncertainty divided by the average value.

$$\% \text{ uncertainty in } \bar{x}: \quad \% \text{ uncertainty} = \frac{U}{\bar{x}} \times 100 \quad (0.7)$$

### EXAMPLE

To illustrate the calculation of  $\bar{x}$  and the associated uncertainty  $U$ , suppose we are measuring the length of a stick and have obtained, in five separate measurements, the results tabulated below.

Length $x$ (cm)	Deviation $\Delta x$ (cm)	$(\Delta x)^2$
54.84	0.43	0.1849
53.92	0.49	0.2401
54.46	0.05	0.0025
54.55	0.14	0.0196
54.30	0.11	0.0121
sum: 272.07		sum: 0.4592

From this information we can calculate

$$\text{Average:} \quad \bar{x} = \frac{272.07 \text{ cm}}{5} = 54.41 \text{ cm}$$

$$\text{Standard deviation:} \quad \sigma = \sqrt{\frac{0.4592}{4}} = 0.3388 \text{ cm}$$

$$\text{Uncertainty:} \quad U = \frac{\sigma}{\sqrt{n}} = \frac{0.3388}{\sqrt{5}} = 0.1515 \text{ cm}$$

Thus our final result for the length is  $54.41 \pm 0.15 \text{ cm}$ .

## SIGNIFICANT FIGURES

---

A number expressing the result of a measurement, or of computations based on measurements, should be written with the proper number of *significant figures*, which just means the number of reliably known digits in a number. The number of significant figures is independent of the position of the decimal point, for example 2.163 cm, 21.63 mm and 0.02163 m all have the same number of significant figures (four).

In doing calculations, all digits which are not significant can be dropped. (It is better to round off rather than truncate). A result obtained by multiplying or dividing two numbers has the same number of significant figures as the input number with the fewest significant figures.

### EXAMPLE

Suppose that we want to calculate the area of a rectangular plate whose measured length is 11.3 cm and measured width is 6.8 cm. The area is found to be

$$\text{Area} = 11.3 \text{ cm} \times 6.8 \text{ cm} = 76.84 \text{ cm}^2$$

But since the width only has two significant figures we can round to two figures and report that the area is  $77 \text{ cm}^2$ .

## GRAPHING, SLOPE AND INTERCEPTS

---

In almost every laboratory exercise, you plot a graph based on the data measured or calculated. A graph lets you visualize the relation between two physical quantities. In plotting a graph, use the following steps:

1. Arrange the data into a table with two columns listing the values for the two measured or calculated quantities. For example, the first column could list the values for time and the second column could list the values for the average velocity.
2. Decide which of the two quantities to plot along each axis. Graphs have two perpendicular axes, the x-axis and the y-axis and by convention you plot the independent quantity along the x-axis and the dependent quantity along the y-axis.
3. Choose the scale for each axis to cover the range of variation of each quantity. You should choose the scale so that the final curve spans the largest area possible on the graph paper.
4. Label each axis with the quantity plotted on that axis and the units used.
5. Mark the main divisions along each axis.
6. Mark each data point on the graph using the values in each row of the data table. Data points must align with the value of each quantity on their respective axes. Make each data point clearly visible on the graph.
7. Fit and draw a smooth curve through the data points so that the curve comes as close as possible to most of data points. Do not force the curve to go exactly through all the points or through the origin of the coordinate system. The fact that not all points lie along the fitted curve just indicates that measurements are subject to some uncertainty.

In many cases the fitted curve is a straight line. The best straight line fit has nearly the same number of data points above and below the line. The equation for a straight line is given by

$$\text{Straight Line} \quad y = mx + b \quad (0.8)$$

The quantity  $b$  is the intercept: it is the value of  $y$  when  $x = 0$ . The quantity  $m$  is the slope of the curve. Given two points on the straight line,  $\{y_1 = mx_1 + b, y_2 = mx_2 + b\}$ , called basis points, the slope is defined as the ratio of the change in  $y$  to the change in  $x$  between these points, as shown in equation 0.9.

Slope  $m = \frac{\Delta y}{\Delta x} = \frac{y_2 - y_1}{x_2 - x_1}$  (0.9)

Basis points are NOT experimental points. They should be chosen as far from each other as possible to increase the precision of  $m$ , as shown in figure 0.1.

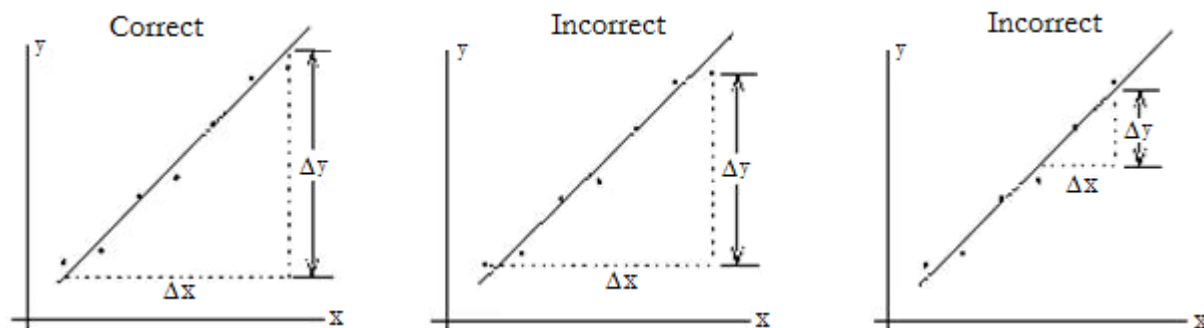

**Figure 0.1** Choosing the correct basis points to calculate the slope

# PLOTTING USING A COMPUTER

After you have some experience making plots by hand, it's easier and more accurate to let a computer do the work. Any standard spreadsheet or plotting software should work. The steps might depend on the type of software you're using. But in Excel, for example, you would start by entering your data in two columns. The first column gives the x values and the second column gives the corresponding y values. Select the data you want to plot, then

- Charts → Scatter → Marked Scatter will produce a plot of your data
- Chart Layout → Trendline → Linear Trendline will add a best-fit line to your plot
- To see the equation of the best-fit line go to Chart Layout → Trendline → Trendline Options... then in the dialog box that appears go to Options and check "Display equation on chart".

Here's a screenshot of a typical Excel plot.

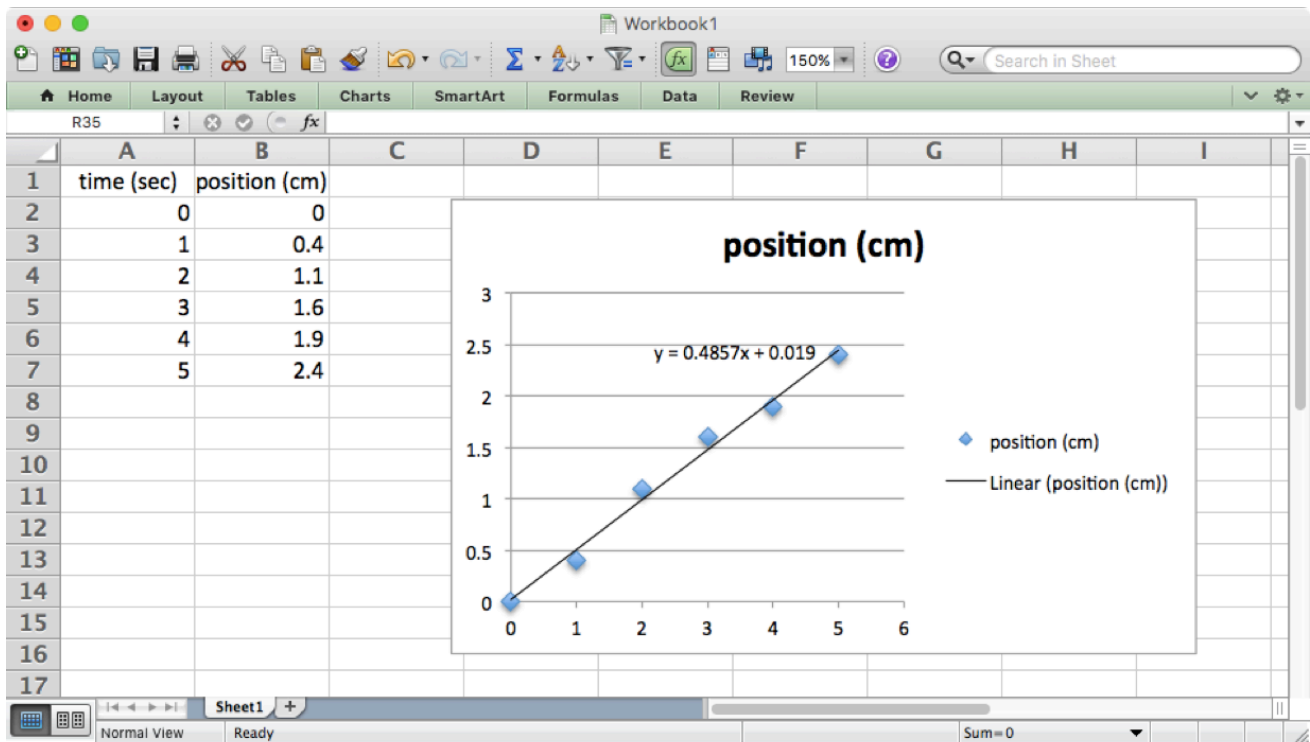

## PRACTICE CALCULATIONS

---

1. The accepted value of the acceleration due to gravity on Earth is  $g = 980 \text{ cm/s}^2$ . When trying to measure this quantity, we performed an experiment and got the following five values for  $g$ .

Trial	$g \text{ (cm/s}^2\text{)}$
1	1004
2	992
3	978
4	985
5	982

a) Find the average value and standard deviation of our measurements of  $g$ .

b) Find the uncertainty in our average value for  $g$ .

c) What is the percent error in our measurement of  $g$ ?

2. A box is moving along a frictionless inclined plane. Experimental measurements of velocity at various times are given below.

time $t \text{ (s)}$	velocity $v \text{ (m/s)}$
0	0
1	5.2
2	10.1
3	14.8
4	19.9
5	25

a) Plot a graph of  $v$  versus  $t$ . Can the data be represented by a straight line? (You can use the graph paper on the next page.)

b) Calculate the slope.

c) What physical quantity does this slope represent?

d) From your estimate of the slope, what would the velocity be at  $t = 10 \text{ s}$ ?

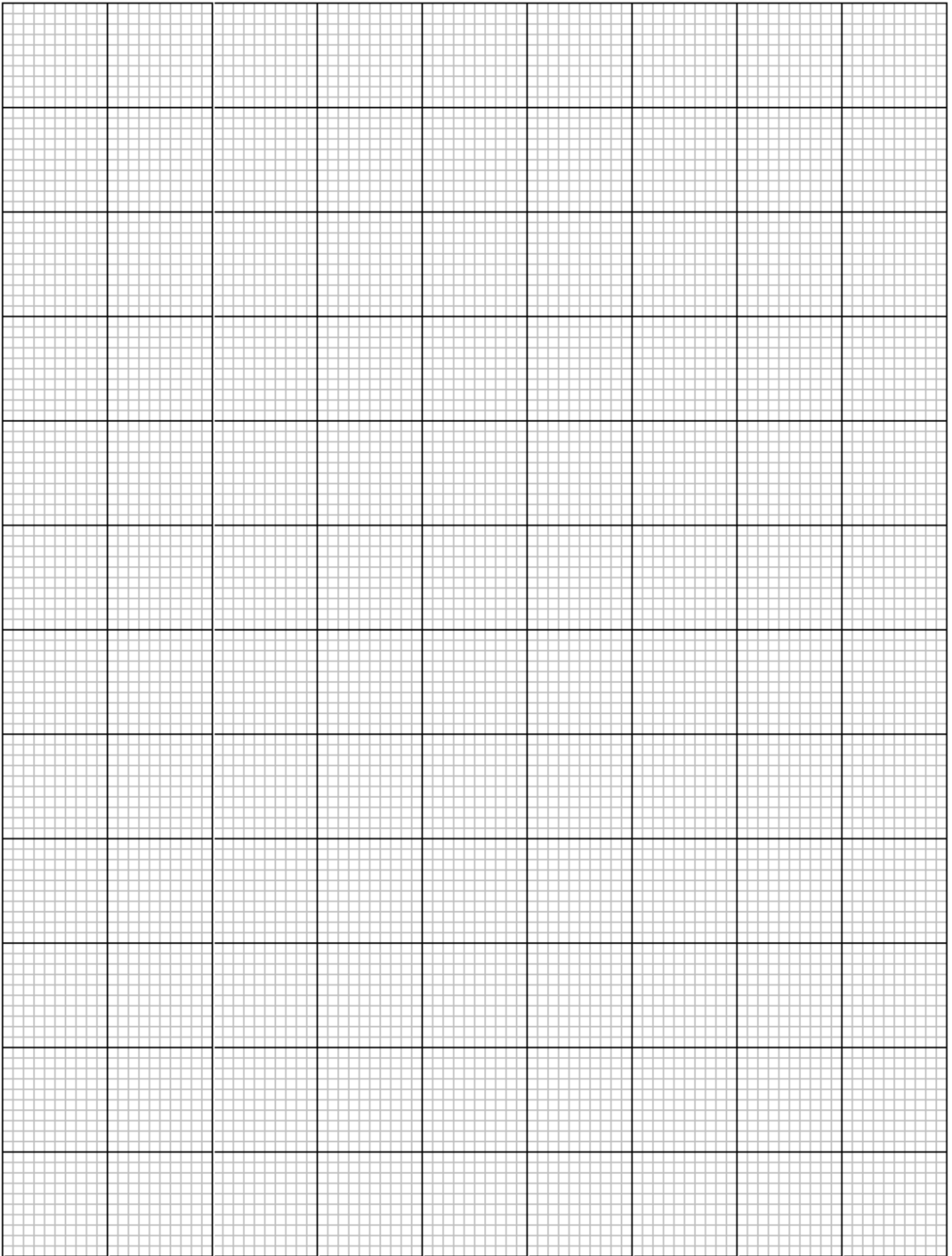

# Introduction: Units and conversions

Every measurement requires a choice of units. It's important to keep track of the units you're using, and to know how to convert between different common units. Here are a few examples.

The SI unit of length is the meter (m). But we sometimes measure lengths in centimeters (cm) or millimeters (mm). The conversions are

$$1 \text{ m} = 100 \text{ cm} = 1000 \text{ mm}$$

For example  $70 \text{ cm}$  is the same as  $0.7 \text{ m}$ , because

$$70 \text{ cm} = 70 \text{ cm} \times \frac{1 \text{ m}}{100 \text{ cm}} = 0.7 \text{ m}$$

The SI unit of mass is the kilogram (kg), but we sometimes measure mass in grams (g). The conversion is

$$1 \text{ kg} = 1000 \text{ g}$$

For example  $150 \text{ g}$  is the same as  $0.15 \text{ kg}$ , because

$$150 \text{ g} = 150 \text{ g} \times \frac{1 \text{ kg}}{1000 \text{ g}} = 0.15 \text{ kg}$$

It's also important to recognize the difference between mass (measured in kilograms) and weight (measured in Newtons). Weight is another name for the force of gravity. It's given by the formula  $F = mg$  where  $m$  is the mass and  $g = 9.8 \text{ m/s}^2$  is the acceleration due to gravity. For example a mass of  $150 \text{ g}$  has a weight of 1.47 Newtons, because  $150 \text{ g}$  is the same as  $0.15 \text{ kg}$  and

$$F = 0.15 \text{ kg} \times 9.8 \text{ m/s}^2 = 1.47 \text{ kg m/s}^2 = 1.47 \text{ N}$$

Note that we had to convert the mass to kilograms in order to get the right answer in Newtons!

# Experiment 1: Acceleration due to free-fall

## OBJECTIVES

---

Acceleration is the rate at which the velocity of an object changes over time. An object's acceleration is the result of the sum of all the forces acting on the object, as described by Newton's second law. Under ideal circumstances, gravity is the only force acting on a freely falling object. In this lab, you measure the displacement of a freely falling object, calculate the average velocity of a falling object at set time intervals, and calculate the object's acceleration due to gravity. The objectives of this experiment are as follows:

1. To measure the displacement of a freely falling object
2. To test the hypothesis that the acceleration of a freely falling object is uniform
3. To calculate the uniform acceleration of a falling object due to gravity,  $g$

## THEORY

---

The movement of the ball occurs in one dimension. Let's describe this dimension with a coordinate  $y$ , that increases downward as the ball falls. The instant when the ball is released is considered to be the initial time  $t = 0$ . The position of the ball at a time  $t$  is given by

$$\text{Position} \quad y(t) = y_0 + v_0 t + \frac{1}{2} g t^2. \quad (1.1)$$

For this to be true, the acceleration  $g$  must be a constant.

If the ball is released from rest, the initial velocity is zero:  $v_0 = 0$ . Therefore,

$$\text{Position} \quad y(t) = y_0 + \frac{1}{2} g t^2. \quad (1.2)$$

## ACCEPTED VALUES

The acceleration due to gravity varies slightly, depending on the latitude and the height above the earth's surface. In this experiment the change in height of the falling object is negligible and can be approximated as 0 km for its entire descent. The acceleration due to gravity at  $40^\circ 52' 21''$  N latitude (the latitude of Lehman College) and 0 km altitude is

$$g = 9.802 \text{ m/s}^2. \quad (1.3)$$



## APPARATUS

The setup, depicted in Figure 1.1, is composed of the following parts:

- electromagnet
- steel ball
- ruler
- mobile photogate
- timer
- power supply
- paper cup

The power supply provides an output of 5V to an electromagnet. When the switch is in the *on* position, the electromagnet can hold the steel ball under it. Once the timer is set to the off position, current stops circulating through the electromagnet, and the ball starts falling.

The sudden change in the current circulating through the magnet produces, following Lenz's law, a short current peak that propagates through the red wire in Figure 1.1. Part of this wire is placed in parallel to the wire attaching the unused photogate to the timer (blue wire in Figure 1.1). The current in the blue wire produces a magnetic field around it. The red wire, when sufficiently close to the blue one, is affected by this magnetic field, which induces a current on it. This current, in the form of a short peak, is interpreted by the timer as an interruption of the photogate, triggering the timer.

Using these principles, the setup allows to have a precise account of the initial time, since the timer starts counting when the ball is released. The second trigger of the timer happens when the ball goes through the photogate. In this moment, the timer stops counting. Therefore, the timer indicates the time (in seconds) it took the ball to go from the top position to the photogate.

Moving the photogate to different heights and measuring the time the ball takes to fall will provide the information necessary to measure the acceleration of gravity.

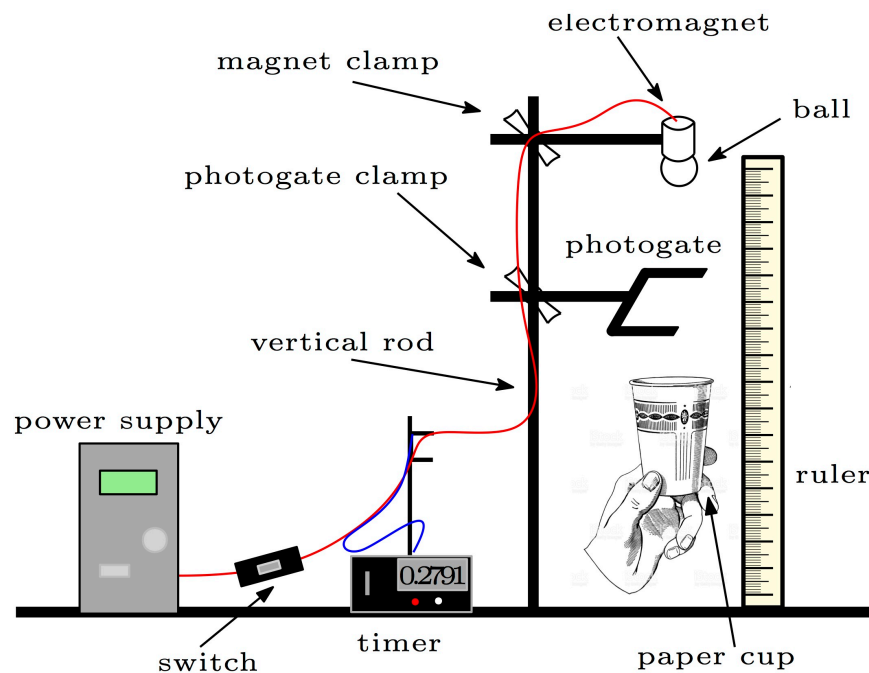

Figure 1.1 Experimental setup

## PROCEDURE

---

1. Adjust the top clamp (the one holding the magnet) in such a way that, with the ruler standing on the table, the center of the ball is at about the same height as the zero of the ruler (see Fig. 1.2).
2. Turn on the timer by moving the switch to the pulse mode.
3. Adjust the height of the bottom clamp (the one holding the photogate) to around 10 cm below the magnet.
4. Align the photogate with the electromagnet so that the ball will pass through the photogate while falling. To do so, you can rotate the clamp around the vertical rod, and adjust the photogate along the horizontal rod. To check that the alignment is correct, hold the top of the ruler right below the magnet so that it doesn't touch the table, and make sure that the ruler goes through the photogate (see Fig. 1.3).
5. Measure the position of the photogate, and record it on the table as a value for  $y$ .
6. Switch on the magnet, and place the ball under it, making sure that it remains there.
7. Hold a paper cup right below the photogate to catch the ball when it falls.
8. While paying attention to the timer, switch the magnet off. The ball will fall. Three outcomes are possible:
  - a. the timer starts and stops immediately, showing a really small value (like 0.0001). In this case, disregard this value, press reset and measure again,
  - b. the timer doesn't start when the magnet is switched off, but it starts later when the ball goes through the photogate. Therefore, the timer keeps running after the ball has fallen. In this case, press reset and measure again,
  - c. the timer starts when the magnet is switched off, and stops when the ball goes through the photogate. In this case, record the time on the table as a value for  $t$ ;

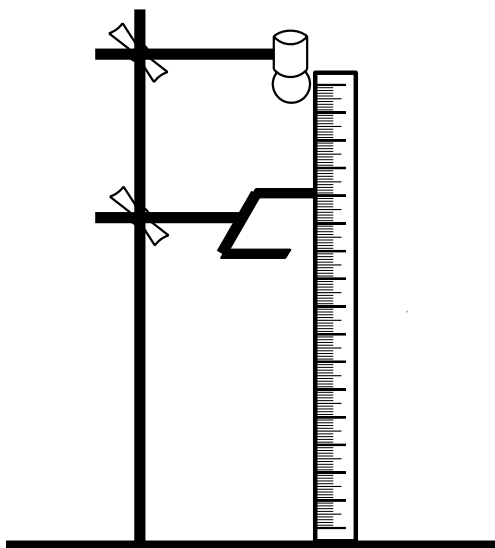

Figure 1.2 Setup for the magnet holder.

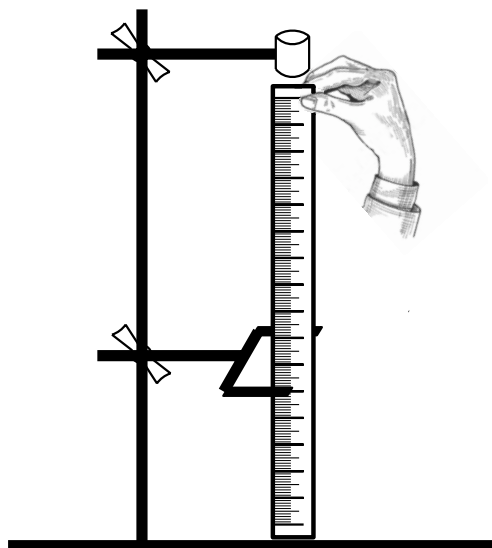

Figure 1.3 Alignment of the photogate.

9. Move the photogate to a position around 10 cm below the previous position.
10. Measure again: repeat steps 4 to 9 until there is no more space to keep the paper cup under the photogate (around 80 cm).

## TROUBLESHOOTING

If the timer never starts when the switch is changed to the *off* position, it could be due to several reasons. First, check that when it is in the *on* position, the electromagnet is able to hold the ball. If this is not the case, it is possible that there is a short in the circuit. Turn the power supply off and ask your instructor for help. If the magnet is able to hold the ball, but the timer doesn't start when switched off, a possible solution is to connect the red and black power cables to the front of the power supply, rather than to the back, and selecting a bit higher voltage (around 6 V).

## DATA

---

Position $y$ (cm)	Time $t$ (s)	time-squared $t^2$ ( $s^2$ )

## CALCULATION AND ANALYSIS

---

1. Fill in the right column of the data table calculating the square of each time value. For simplicity, you can do this on a spreadsheet computer software.
2. Using a spreadsheet software, make a plot of distance *v*s time squared for the points in the second and third columns of the table. Assign distance (*y*) to the vertical axis, and time squared ( $t^2$ ) to the horizontal axis.
3. make a fit of the plotted data to a straight line using the spreadsheet software.
4. Find the slope and the intercept of the best fit straight line. A general straight line is given by  $y = ax + b$ , where *a* is the slope and *b* the intercept. Comparing this equation to (1.2), find  $y_0$  and *g* from the slope and the intercept of the fit.
5. Calculate the percent difference between the value you obtained for *g* and the accepted value (1.3).
6. Describe the meaning of  $y_0$  and whether or not the value you obtained agrees with your expectations.

# Experiment 2: Static Equilibrium

## OBJECTIVES

---

When all the external forces acting on object do not accelerate the object, the object is in a state of mechanical equilibrium. If the object is also at rest, the object is in a state of static equilibrium. In this experiment, you arrange sets of forces to put an object into static equilibrium, measure the vector quantities of these forces, and calculate the net force acting upon an object in equilibrium. The objectives of this experiment are as follows:

1. To measure vector quantities for forces using the force table
2. To calculate the net force on an object using vector addition
3. To test the hypothesis that an object in equilibrium has no net force acting upon it

## THEORY

---

According to Newton's second law of motion, an object accelerates in direct proportion to the net force acting on it. An object in static equilibrium is not moving, so has an acceleration of zero, and the net force on the object is also zero. Therefore, the necessary condition for equilibrium is that the vector sum of all external forces acting on the object is zero, as shown in equation 2.1.

$$\text{Equilibrium} \quad \vec{F}_{total} = \sum_i \vec{F}_i = 0 \quad (2.1)$$

In this experiment, you apply forces to an object in two dimensions until it is in static equilibrium, measure the vector forces, and calculate the vector sum. All forces are applied in the plane (two dimensions), so one can project the forces on the  $x$ - and  $y$ -axes as shown in equations 2.2.

$$\begin{aligned} \text{2-D Equilibrium} \quad F_{total,x} &= \sum_i F_{i,x} = 0 \\ F_{total,y} &= \sum_i F_{i,y} = 0 \end{aligned} \quad (2.2)$$

To decompose a force vector into its  $x$  and  $y$  components, it is convenient to choose the  $x$ -axis along the direction  $\phi = 0^\circ$  and the  $y$ -axis along the direction  $\phi = 90^\circ$ . Then the components of the forces are shown in the pair of equations 2.3.

$$\text{Component Forces} \quad F_{i,x} = F_i \cos \phi_i, \quad F_{i,y} = F_i \sin \phi_i \quad (2.3)$$

## ACCEPTED VALUES

The accepted value for the sum of the forces on an object in equilibrium is 0.

## APPARATUS

---

- Horizontal force table
- four pulleys
- one metal ring
- four cords
- four weight hangers
- a degree scale
- Assortment of known weights.

## THE FORCE TABLE

A force table consists of a circular platform supported by a heavy tripod base. The circular platform has a graduated degree scale around its rim and a small peg located directly in the center. Four cords are attached to a metal ring placed over a peg in the center of the platform and the cords are connected over pulleys to weight hangers, as shown in Figure 2.1.

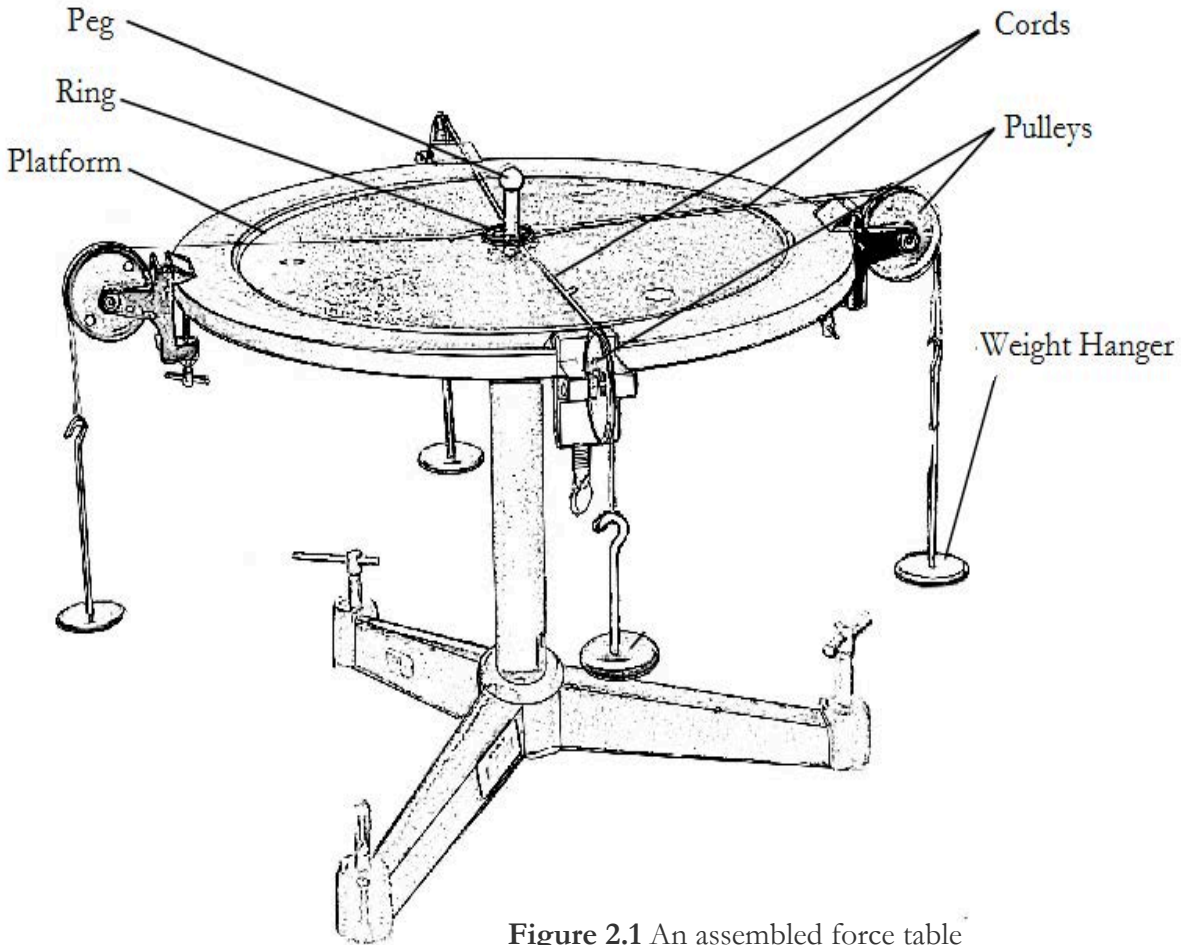

Figure 2.1 An assembled force table

Tension forces are applied to the ring by varying the total mass on each weight hanger and moving the pulleys to change the direction in which each force acts. The ring is in a state of static equilibrium when it is over the peg but not touching the peg, as shown in figure 2.2.

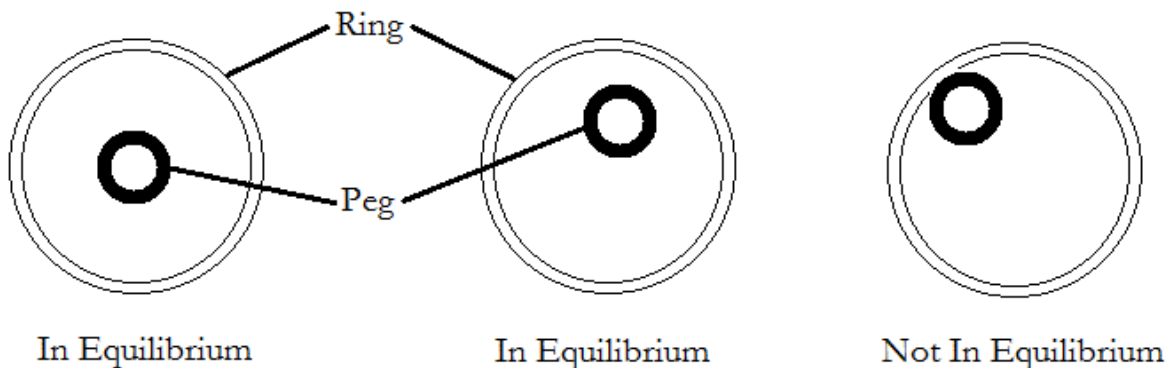

Figure 2.2 Overhead view of ring and peg positions for system in and not in equilibrium

## PROCEDURE

---

1. Mount a pulley at  $0^\circ$  and have a mass of 250 g to the cord running over it. *Remember: the total hanging mass is the mass of the hanger plus any additional masses that are added to it.*
2. Mount a second pulley at  $60^\circ$  with a total of 350 g.
3. Holding a third cord in your hand, find the general direction in which a third force should act in order to balance the system (by tugging away from the previously hanged weights). Screw the pulley in place and add weights to the holder after running it over the pulley. Adjust the hanging mass and/or the position of the pulley to bring the system is in static equilibrium (see Figure 2.2).
4. Record masses, angles and forces in the data sheet labeled Trial 1.
5. Repeat step 1 through 4 using a  $45^\circ$  angle between the two loads. Record your results in the data sheet labeled Trial 2.
6. Set up four pulleys and suspend unequal loads on the cords running over them. Arrange the system so that it is in equilibrium, and record the masses and angles. Do not have any two cords form an angle of  $180^\circ$ . Record your results in the data sheet labeled Trial 3.
7. Suppose you place a mass,  $m = 300$  g, at  $\phi = 210^\circ$  mark. Compute the masses  $m_a$  and  $m_b$  you would place at  $0^\circ$  and  $90^\circ$  to balance mass  $m$ . Try it, and see if your solution is correct. Report what masses you had to place at  $0^\circ$  and  $90^\circ$  to balance the mass at  $210^\circ$ .

### REPORTING % ERROR WHEN THE ACCEPTED VALUE IS ZERO

In this experiment, the accepted value of the total force is zero. If you could measure all the forces on the ring with perfect precision, you would find that the net force vanishes. If zero is inserted into our initial % Error equation (0.2), the result is undefined because the denominator is zero. Due to experimental errors and measurement uncertainties, the calculated net force isn't zero. A useful way to characterize the accuracy of our measurements is to divide the magnitude of net force,  $|F_{total}|$ , by the sum of the magnitudes of all the individual forces,  $\sum_i |F_i|$ , multiplied by 100% as shown in equation 2.4.

$$\% \text{ Discrepancy} = \frac{|F_{total}|}{\sum_i |F_i|} \times 100\% \quad (2.4)$$

The quantities appearing in this formula are

$$\text{Magnitude of Net Force} \quad |F_{total}| = \sqrt{F_{x,total}^2 + F_{y,total}^2} \approx 0 \quad (2.5)$$

$$\text{Individual Magnitude Sum} \quad \sum_i |F_i| = \sum_i m_i g \quad (2.6)$$

## CALCULATION AND ANALYSIS

---

1. Draw a picture showing the three forces for Trial 1. (This is sometimes called a free body diagram.) Be sure to label each vector's direction and magnitude.
2. Calculate the component forces for each force vector,  $F_{ix}$  and  $F_{iy}$ , using equation 2.3.
3. Calculate  $|F_{total}|$  and  $\sum_i |F_i|$  using equations 2.5 and 2.6, given below.
4. Calculate the % discrepancy of the force calculations using equation 2.4.
5. Repeat steps 2 through 4 using data from trials 2 and 3.
6. In procedure 7, was the system in equilibrium? Justify your results by explicitly showing your calculations.
7. What are the sources of experimental error in this experiment? Do any of these factors help the ring achieve static equilibrium?

## DATA

---

### Trial 1

$i$	$m_i$ (grams)	$F_i = m_i g$ (Newtons)	$\phi_i$ (°)
1			0.0
2			60.0
3			

### Trial 2

$i$	$m_i$ (grams)	$F_i = m_i g$ (Newtons)	$\phi_i$ (°)
1			0.0
2			45.0
3			

### Trial 3

$i$	$m_i$ (grams)	$F_i = m_i g$ (Newtons)	$\phi_i$ (°)
1			
2			
3			
4			



# Experiment 3: Newton's Second Law

## OBJECTIVES

---

Newton's second law predicts that acceleration is a function of force and mass. To test this mathematical relationship, a good experiment must isolate each contributing component and vary it independently of the others. In this experiment, you measure the acceleration of an object by varying the force acting upon the object without changing its mass and by varying the object's mass without changing the force. The objectives of this experiment are as follows:

1. To measure the linear acceleration of objects acted on by external forces.
2. To predict the acceleration of an object by applying Newton's Second law.
3. To test the predictions using calculations and graphical methods.

## THEORY

---

Newton's second law in vector form is shown in equation 3.1.

$$\text{Newton's second law} \quad \vec{F} = m\vec{a} \quad (3.1)$$

Here  $\vec{F}$  is the net force acting on an object,  $m$  is the mass of the object, and  $\vec{a}$  is its acceleration. If the force is constant, as, for instance, the force of gravity, the object moves with constant acceleration. Newton's second law also applies to systems of bodies considered as a whole, like two masses connected by a cord. Each of the objects in this experiment moves along a straight line. Thus it is sufficient to consider projections of the vectors on the direction of motion and we can remove the vector notation:  $F = ma$ .

In this experiment we measure the acceleration of a system consisting of a glider moving along a nearly frictionless air track, and a falling/hanging mass tied to the glider via a cord. The net force on the system is exerted by the gravitational force acting on the hanging mass over a low-friction pulley. If you ignore friction, the acceleration of the system according to Newton's second law is shown in equation 3.2.

$$\text{Acceleration of the glider} \quad a = g \frac{m}{M} \quad (3.2)$$

Here  $m$  is the hanging mass,  $M$  is the total moving mass, and  $g$  is the free-fall acceleration due to gravity.

The acceleration of an object is the rate of change in its velocity. If the velocity changes by an amount  $\Delta v$  during a time  $\Delta t$ , the average acceleration is shown in equation 3.3.

$$\text{Average acceleration} \quad \bar{a} = \frac{\Delta v}{\Delta t} \quad (3.3)$$

Here  $\Delta t = t_2 - t_1$  and  $\Delta v = v_2 - v_1 \equiv v(t_2) - v(t_1)$ . If  $\Delta t$  becomes very small, equation 3.3 gives the instantaneous acceleration at  $t_2 \cong t_1$ . For the motion with constant acceleration that we study in this experiment, the average and instantaneous accelerations are the same.

In the experiment, the glider goes through two photo gates,  $G_1$  and  $G_2$ , its flag interrupting the light path in the gates. The computerized system measures three time intervals,  $T_1$ ,  $T'$ , and  $T_2$ , as depicted in figure 3.1.

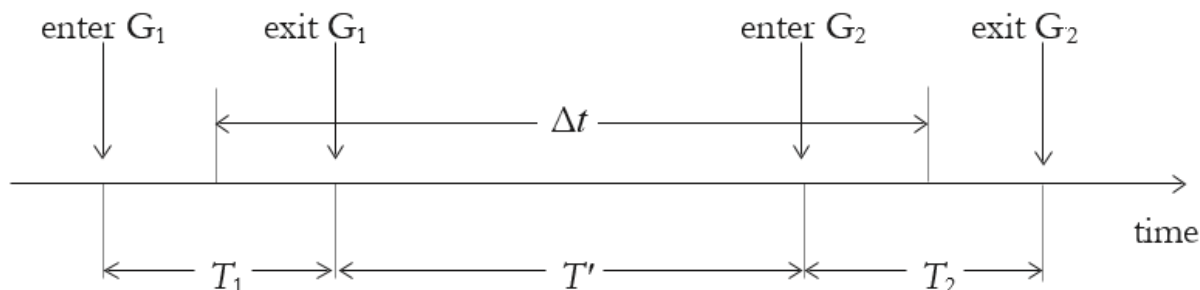

**Figure 3.1** The motion of the glider flag through photo gates  $G_1$  and  $G_2$

Time interval  $T_1$  begins when the flag enters the first gate,  $G_1$ . As the flag clears this gate,  $T_1$  ends and the second interval,  $T'$ , begins. Then, as the flag enters the second gate,  $G_2$ ,  $T'$  ends and the third interval,  $T_2$ , begins. It ends when the flag clears gate  $G_2$ .

From the length of the flag  $L$  measured in this experiment, you can calculate the average velocities of the glider crossing gates 1 and 2, as shown in equation 3.4.

$$\text{Average velocities} \quad \bar{v}_1 = \frac{L}{T_1}, \quad \bar{v}_2 = \frac{L}{T_2} \quad (3.4)$$

For motion with constant acceleration the velocity changes linearly with time, so these average velocities coincide with instantaneous velocities in the middle of the time intervals  $T_1$  and  $T_2$ . Thus the time interval  $\Delta t$  corresponding to the velocity change  $\Delta v = v_2 - v_1$  is shown in equation 3.5.

$$\text{Elapsed time} \quad \Delta t = T' + \frac{1}{2}T_1 + \frac{1}{2}T_2 \quad (3.5)$$

Therefore, the formula for experimentally determining the acceleration is the difference of the average velocities divided by the elapsed time, as shown in equation 3.6.

$$\text{Acceleration (experimental)} \quad a = \frac{\Delta v}{\Delta t} = \frac{\left( \frac{L}{T_2} - \frac{L}{T_1} \right)}{\left( T' + \frac{1}{2}T_1 + \frac{1}{2}T_2 \right)} \quad (3.6)$$

## ACCEPTED VALUES

The expected value of the acceleration for all of the mass distributions in this experiment is the result of equation 3.2. For Part A, you change the masses of the falling/hanging object and the total moving mass, so obtain a different expected value for each setup.

For Part B, the same force is acting in each case, and therefore Newton's second law predicts that the product of the total moving mass  $M_1$  and its acceleration  $a_1$  is equal to the product of any other mass and its acceleration under the same conditions, as shown in equation 3.7.

## APPARATUS

---

- glider
- air track
- photo gates
- computer with PASCO interface.
- cord
- pulley
- flags
- earth's gravity

### THE AIR TRACK AND GLIDERS

In this experiment you measure the acceleration of a system consisting of a glider moving along a nearly frictionless air track, and a falling/hanging mass tied to the glider via a string, as shown in figure 3.2.

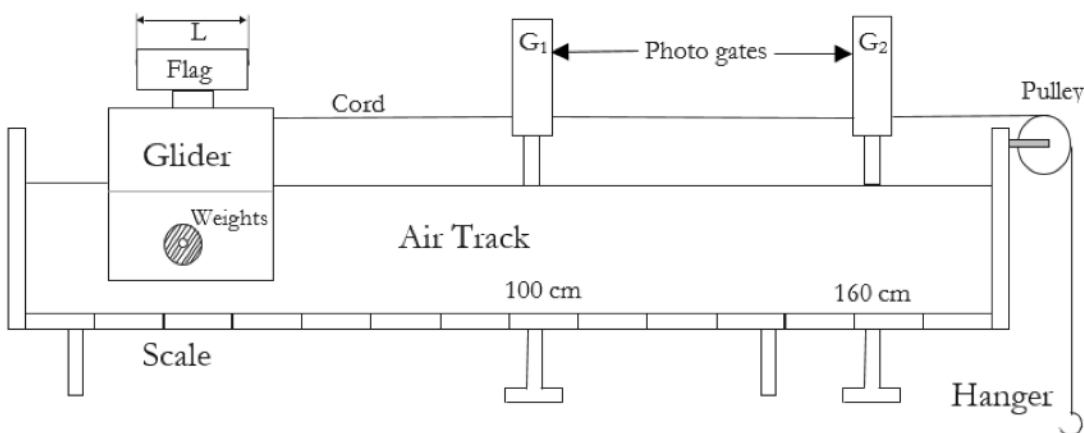

**Figure 3.2** System consisting of a glider on a nearly-frictionless air track connected to a hanging weight by a cord over a low-friction pulley

The net force on the system is exerted by the gravitational force acting on the hanging mass. The glider is supported by a cushion of air coming out of the holes in the horizontal frame, so that friction is almost eliminated and can be neglected.

The glider has two rods on which weights may be set. You should have four fifty gram weights (shiny cylinders) and five 5 gram weights (flat slotted disks). The slotted disks stay firmly on the glider if the fifty-gram weights are placed on top of them.

Your experimental station also includes a pair of photo gates, connected to a computer, which function as an electric stopwatch.

## PROCEDURE

---

### PART A: ACCELERATION AS A FUNCTION OF FORCE WITH A CONSTANT MASS

1. Measure the length of the flag, using the scale on the air track and record this as length of the flag,  $L$ .

2. Measure the mass of the weight hanger and record this value as the mass of the weight hanger,  $m_{\text{hanger}}$
3. Put two 50 gram weights, five 5 gram weights, the flag, the cord, and the weight hanger on the glider, and weigh everything together. Record this as the total moving mass,  $M$ , in the data table for Part A.
4. Place Photo gate  $G_1$  at 110 cm, and photo gate  $G_2$  at 160 cm. Make sure that  $G_1$  is connected to “DIGITAL CHANNELS” input 1 of the interface, and  $G_2$  to input 2, respectively.
5. Place the glider on the air track. Turn on the blower and run the glider slowly through the gates. Make sure that the flag blocks the light but does not hit the gates. Then turn off the blower
6. Turn on the PC with Interface turned ON and log in as “student” using the password provided by the lab instructor.
7. From desktop click the icon “Newton Second Law”.
8. Move the glider to 100 cm on the air track.
9. Place two 5g weights and one 50 g weight onto the rods on each side of the glider.
10. Let the cord fall over the pulley at the end of the track and attach a 5 gram weight to the hanger, as shown in figure 3.2.
11. Measure the motion of the glider with a 5 gram hanging/falling weight by performing the following steps:
  - A. Click “Start” on the PC monitor: The system is ready to collect the data.
  - B. Hold the glider at 100 cm and turn on the air blower, wait for the pitch of the blower to reach a stationary level.
  - C. Let the glider go. The times  $T_1$ ,  $T'$ , and  $T_2$ , respectively, appear in the first row of the table with columns labeled “Timer 1”, “Timer2”, and “Timer 3”. Be careful not to let the glider bounce back into the second gate!
  - D. Remove the glider from the air track and replace it at 100 cm without disturbing the photo gates. Do not stop the PC data acquisition after the glider crosses the two gates and do not switch off the air blower.
  - E. Repeat runs described by steps C and D four times. Each time a new row in the table is added. If one or more of the runs yields times substantially different from the results of other runs, an error occurred. In this case clear the data sheets and repeat the experiment.
  - F. Record the average values for  $T_1$ ,  $T'$ , and  $T_2$  on your data sheet for part A.
  - G. To clear all entries, click “Stop”, and from “Experiment” menu click “Clear ALL Data Runs”.
12. Repeat step 11 by increasing the hanging mass by transferring 5 gram weights from the glider to the hanger. For each value of the mass on the hanger  $m = 5, 10, 15, 20,$  and 25 grams (plus the mass of the hanger  $m_{\text{hanger}}$  itself) make five runs. Record the average times  $T_1$ ,  $T'$ ,  $T_2$  in the data sheet for Part A. Always transfer weights from the glider to the hanger so the total mass of the system remains constant. When removing weights from the glider, ensure that the weights on each side of the glider are approximately equal, otherwise the glider can slip off the air cushion and add friction to your measurements.

## **PART B: ACCELERATION AS A FUNCTION OF MASS WITH CONSTANT FORCE**

1. Put two 50 gram weights, one 5 gram weight, the flag, the cord, and the weight hanger on the glider, and weigh everything together. Record this as the total moving mass,  $M_1$ , in the data Section for Part B.

- Place the glider on the track. Place the 50 g weights on the rods, one on each side of the glider. Let the cord fall over the pulley at the end of the track and attach a 5 gram weight to the hanger, as shown in figure 3.2.
- Measure the motion of the glider attached to a 5 gram hanging/falling weight using the same procedure as Part A. Do five runs, and record the average value of  $T_1$ ,  $T'$ , and  $T_2$  in the first row of the data table for Part B.
- Remove the two 50 gram weights from the glider. Calculate the resulting mass  $M_2$  using the value of  $M_1$  and enter  $M_2$  in the data table for Part B.
- Measure the motion of the glider attached to a 5 gram hanging/falling weight using the same procedure as Part A. Record the average values of  $T_1$ ,  $T'$ ,  $T_2$  in the data table for Part B.

## DATA

---

### PART A

$m$ (g)	$T_1$ (s)	$T'$ (s)	$T_2$ (s)
$5 + m_{\text{hanger}}$			
$10 + m_{\text{hanger}}$			
$15 + m_{\text{hanger}}$			
$20 + m_{\text{hanger}}$			
$25 + m_{\text{hanger}}$			

### PART B

$M$ (g)	$T_1$ (s)	$T'$ (s)	$T_2$ (s)

## CALCULATION AND ANALYSIS

---

- Calculate the acceleration for each of your five  $m$  values using your data from Part A. To do this use equation 3.6 and the average values for  $T_1$ ,  $T'$ , and  $T_2$  recorded by the computer.
- Calculate and record the accelerating force,  $F = mg$ , for each of your five  $m$  values.
- Draw a graph of the accelerating force  $F$  versus the acceleration  $a$ , with  $a$  on the  $x$ -axis. Draw a best fit straight line through the five points on your graph.
- Find the slope of the straight line you fit to the points and compare it with the total mass of the system  $M$ . By what percent does the slope differ from  $M$ ?
- Calculate the acceleration for your two  $M$  values using your data from Part B. To do this use equation 3.6 and the average values for  $T_1$ ,  $T'$ , and  $T_2$  recorded by the computer.
- Using the average acceleration  $a_1$  of the system with mass  $M_1$ , and the average acceleration  $a_2$  for mass  $M_2$  from Part B, calculate and compare  $M_1 a_1$  and  $M_2 a_2$ . By what percent do the two values differ?

# Experiment 4: Conservation Laws in Collisions

## OBJECTIVES

---

The conservation laws for linear momentum and energy state that the total momentum and energy of an isolated system remain constant. This is true at all times in the system, even if some momentum or energy is transferred from one component of the system to another. In this experiment, you measure the motion and mass of a system comprised of colliding objects and calculate the energy and momentum of the system before and after the collision. The objectives of this experiment are as follows:

1. To measure the motion of objects that undergo elastic and inelastic collisions
2. To calculate changes in energy and momentum in elastic and inelastic collisions
3. To test the conservation laws for linear momentum and energy

## THEORY

---

A conservation law states that a measurable property of an isolated physical system does not change with time. Two conservation laws are particularly important: conservation of linear momentum and conservation of energy

### CONSERVATION OF LINEAR MOMENTUM

The law of conservation of linear momentum states that in a system where the sum of external forces is zero, the total momentum of a system does not change. In a system composed of  $n$  objects, the total momentum is given by the vector sum shown in equation 4.1.

$$\text{Total Momentum} \quad p = \sum_{i=1}^n m_i \vec{v}_i = m_1 \vec{v}_1 + m_2 \vec{v}_2 + \dots + m_n \vec{v}_n \quad (4.1)$$

Here,  $m_i$  and  $\vec{v}_i$  are the mass and velocity of object number  $i$ , respectively. As the objects interact with one another, the individual velocities may change, but the total momentum  $p$  remains constant. In this experiment, you study collisions between two objects. Before the collision suppose one object has mass  $m_1$  and is moving at velocity  $\vec{v}_{1i}$  and the other object has mass  $m_2$  and is moving at velocity  $\vec{v}_{2i}$ . After the collision their velocities are  $\vec{v}_{1f}$  and  $\vec{v}_{2f}$ . The law of conservation of momentum predicts that the total momentum is the same before and after the collision, as shown in equation 4.2.

$$\text{Conservation of Momentum} \quad m_1 \vec{v}_{1i} + m_2 \vec{v}_{2i} = m_1 \vec{v}_{1f} + m_2 \vec{v}_{2f} \quad (4.2)$$

Velocities are vector quantities, with direction as well as magnitude. In this experiment they act along a straight line so they have components only along one axis. However velocity in one direction (e.g. to the right) must be taken as positive while a velocity in the opposite direction must be taken as negative.

In an inelastic collision, two objects stick together and become one combined object. Momentum is still conserved, but the calculation changes to meet the new condition as shown in equation 4.3.

$$p \text{ for Inelastic Collisions} \quad m_1\vec{v}_{1i} + m_2\vec{v}_{2i} = (m_1 + m_2)\vec{v}_f \quad (4.3)$$

Here, before the collision one object has mass  $m_1$  and is moving with velocity  $\vec{v}_{1i}$  and the other object has mass  $m_2$  and is moving with velocity  $\vec{v}_{2i}$ . After the collision the combined mass is  $(m_1 + m_2)$  and the velocity is  $\vec{v}_f$ .

## CONSERVATION OF ENERGY

The kinetic energy of an object of mass  $m$  moving at speed  $|\vec{v}|$  is defined as  $\frac{1}{2}m|\vec{v}|^2$ . Speed is the magnitude of the velocity vector; both speed and kinetic energy are scalar quantities. The law of conservation of energy states that the total energy of an isolated system is constant, but this does not imply that the kinetic energy is constant. In a collision, the objects may be deformed or set into vibration. Then some or all of the kinetic energy is converted into heat or other forms of energy.

You study two kinds of collisions in this experiment: collisions which are nearly elastic (only a small fraction of the kinetic energy is lost), and inelastic collisions, in which a large fraction of the kinetic energy is lost. By using a rubber band so that the gliders bounce away from each other with little loss of kinetic energy, we obtain (nearly) elastic collisions. In an elastic collision the total kinetic energy does not change, as shown in equation 4.4.

$$\text{Energy in Elastic Collisions} \quad KE_i = KE_f \quad (4.4)$$

Here  $KE_i$  and  $KE_f$  are the initial and final kinetic energies, as shown in equations 4.5 and 4.6.

$$\text{Initial Kinetic Energy} \quad KE_i = \frac{1}{2}m_1|\vec{v}_{1i}|^2 + \frac{1}{2}m_2|\vec{v}_{2i}|^2 \quad (4.5)$$

$$\text{Final Kinetic Energy} \quad KE_f = \frac{1}{2}m_1|\vec{v}_{1f}|^2 + \frac{1}{2}m_2|\vec{v}_{2f}|^2 \quad (4.6)$$

If we fix a system so that the objects stick together after colliding, we obtain the maximum possible loss in kinetic energy. The initial and final kinetic energies for an inelastic collision when one object has no initial velocity ( $|\vec{v}_{2i}| = 0$ ) are shown in equations 4.7 and 4.8.

$$\text{Initial Kinetic Energy} \quad KE_i = \frac{1}{2}m_1|\vec{v}_{1i}|^2 \quad (4.7)$$

$$\text{Final Kinetic Energy} \quad KE_f = \frac{1}{2}(m_1 + m_2)|\vec{v}_f|^2 \quad (4.8)$$

To calculate the percent kinetic energy lost in any collision, use equation 4.9.

$$\text{Percent Kinetic Energy Lost} \quad \%KE_{lost} = \frac{KE_i - KE_f}{KE_i} \times 100 \quad (4.9)$$

Here,  $KE_i$  and  $KE_f$  are the energies calculated in equations 4.5 through 4.8.

## ACCEPTED VALUES

In this experiment the mass and velocity values depend on the experimental conditions, so there is no single accepted value. The accepted value of the total energy in a collision is the kinetic energy of the objects before colliding  $KE_i$ , given in equation 4.5 (elastic) or equation 4.7 (inelastic).

For momentum, you measure the masses of the objects and test to what degree the velocities support the law of conservation of momentum. For an inelastic collision when one object has no initial velocity ( $|\vec{v}_{2i}| = 0$ ), we can rearrange equation 4.3 algebraically to compare the ratio of the initial and final masses to the initial and final velocities, as shown in equation 4.10.

$$\text{Ratio for Inelastic Collisions} \quad \frac{|\vec{v}_f|}{|\vec{v}_{1i}|} = \frac{m_1}{(m_1 + m_2)} \quad (4.10)$$

Here, the ratio of the masses before and after the collision  $\frac{m_1}{(m_1+m_2)}$  is the accepted value to test the law of conservation of momentum.

For an elastic collision, we can rearrange equation 4.2 algebraically to compare the ratio of the initial and final masses to the initial and final velocities, as shown in equation 4.11.

$$\text{Ratio for Elastic Collisions} \quad \frac{v_{2f} - v_{2i}}{v_{1i} - v_{1f}} = \frac{m_1}{m_2} \quad (4.11)$$

Since  $v_{1i}$  and  $v_{2f}$  are negative we can multiply numerator and denominator by (-1) and write this as

$$\text{Ratio for Elastic Collisions} \quad \frac{|v_{2f}| + |v_{2i}|}{|v_{1i}| + |v_{1f}|} = \frac{m_1}{m_2} \quad (4.12)$$

Hence the ratio of the masses  $\frac{m_1}{m_2}$  is the accepted value to test the law of conservation of momentum.

## APPARATUS

---

- Air track
- 2 gliders
- weights
- photo-gates
- elastic and inelastic bumpers
- 2 metal flags
- computer with PASCO interface

## COLLIDING GLIDERS ON AN AIR TRACK

The colliding objects in this experiment are gliders, mounted on an air track to minimize friction. The photo gates are used to measure the speed of the gliders, as in experiment 3. You use the inelastic bumpers for inelastic collisions, and the elastic bumpers for nearly elastic collisions.

The inelastic bumpers stick together when two gliders collide. The pin on one glider sticks in the wax-filled hole on the other, as shown in figure 4.1. The flag is used to measure the speed of a glider before and after the collision by timing its passage through the photo gates.



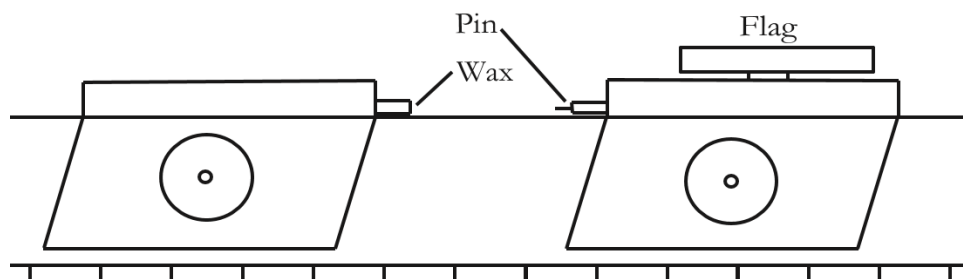

**Figure 4.1** Gliders fitted with the inelastic bumpers and one flag

The elastic bumper prevents the loss of energy due to heat and vibration when two gliders collide. The bumper is attached to one glider only, as shown in figure 4.2. The flags are used to measure the speed of both gliders before and after the collision by timing their passage through the photo gates.

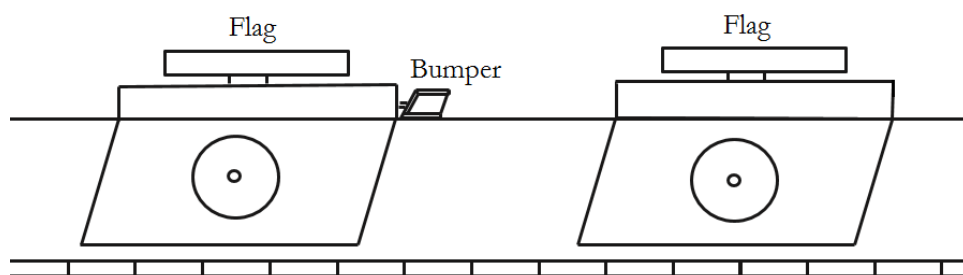

**Figure 4.2** Gliders fitted with flags and one elastic bumper

## PROCEDURE

---

### PART A: INELASTIC COLLISION

1. Attach the flag to one glider and the inelastic bumpers to both gliders.
2. Weigh the two gliders individually. Record the mass of the glider with the flag as  $m_1$  and the mass of the other glider as  $m_2$  in the data table for Part A.
3. Measure the length of the flag and record it as  $L$  in the data table for Part A.
4. Adjust the height of the photo-gates so that the light is blocked by the flag, not by the entire body of the glider.
5. Place the photo-gates at about 70 and 130 cm.
6. Place the glider with the flag on the air track. Turn on the blower and run the glider slowly through the gates. Make sure that the flag blocks the light but does not hit the gates. Then turn off the blower
7. Turn on your computer.
8. Double-click the icon labeled "Conservation of energy" in your desktop.
9. Set up the two gliders as shown in figure 5.3 with glider  $m_1$  to the right or left of both photo-gates and glider  $m_2$  between the photo-gates.

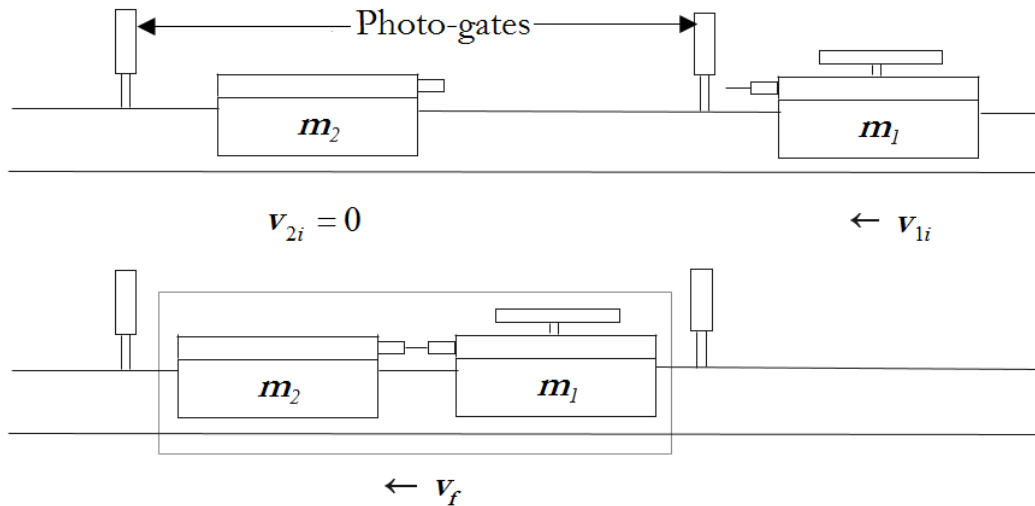
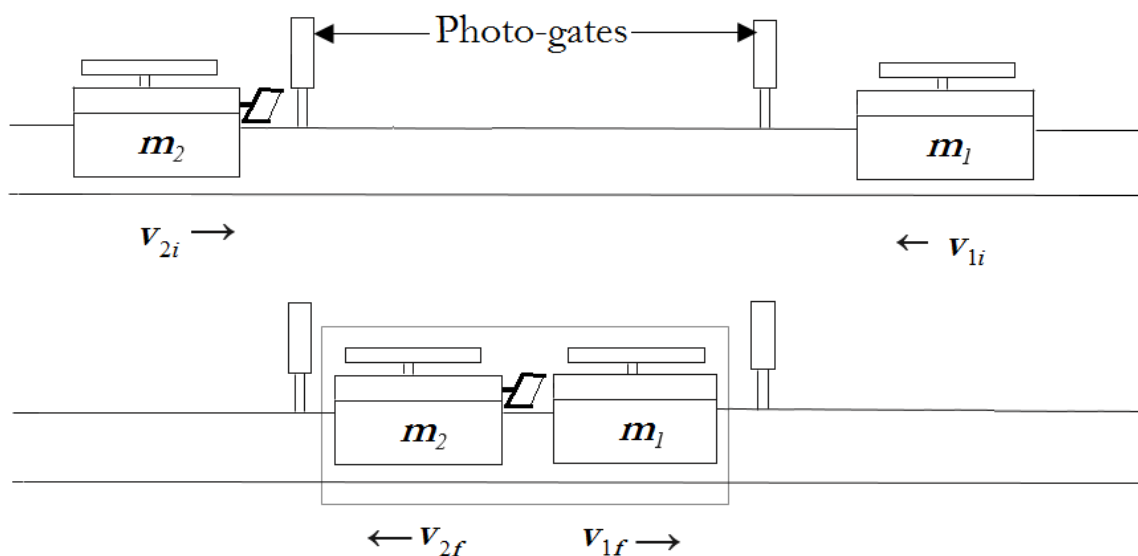

**Figure 4.3** The initial and final motion of the gliders in an inelastic collision

10. Choose "Start" on the computer interface.
11. Turn on the air track blower.
12. Release glider  $m_2$  (without moving it) and push glider  $m_1$  towards glider  $m_2$  at a moderate speed. Be sure you have finished pushing before the flag enters the photo-gate. Glider  $m_1$  should strike glider  $m_2$  and stick to it, and the two gliders together should pass through the second photo-gate. Be sure the gliders collide after the flag has passed through the first photo-gate, and that the gliders do not bounce back between the photo-gates.
13. Repeat step 12 four more times.
14. Choose "Stop" on the computer interface.
15. Record the values for  $T_1$  and  $T_2$  for all five trials from the computer in the data table for Part A.

### PART B. ELASTIC COLLISION

1. Remove the inelastic bumpers and set them aside.
2. Attach a flag and elastic bumper to the glider without a flag.
3. Weigh each glider and record the mass of the one with the bumper as  $m_1$  and the other as  $m_2$  in the data table for Part B.
4. Measure the length of the flags and record them as  $L_1$  and  $L_2$  in the data table for Part B.
5. Place the photo-gates near 90 and 160 cm.
6. Place the gliders on the air track. Turn on the blower and run the gliders slowly through the gates. Make sure that the flag on glider  $m_1$  blocks photo-gate 1 and the flag on glider  $m_2$  blocks photo-gate 2. Then turn off the blower.
7. Place the gliders as in the upper diagram in figure 5.4, with glider  $m_1$  to the right of both photo-gates and glider  $m_2$  to the left of both photo-gates.



**Figure 4.4** The initial and final motion of the gliders in an elastic collision

8. Turn on the blower and choose “Start” on the computer interface.
9. Push the gliders towards each other so that they collide between the gates. Be sure you have stopped pushing them before they enter the gates. The computer records the time it takes for each glider to pass through the photo-gates, both before (*i*) and after (*f*) the collision. The computer records the passage of the gliders before the collision in one row and the passage of the gliders after the collision in the next row. Record the data from the first row as  $T_{1i}$  and  $T_{2i}$  in the data table for Part B. Record the data from the second row as  $T_{1f}$  and  $T_{2f}$ .
10. Without choosing “Stop” on the computer, repeat procedure 9 four more times so that the gliders collide a total of five times, which the computer records in a total of 10 rows.
11. Choose “Stop” on the computer interface.
12. Record the data from each pair of rows on the computer into the data table for Part B. Record the data from the first row of each pair as  $T_{1i}$  and  $T_{2i}$  and the data from the second row of each pair as  $T_{1f}$  and  $T_{2f}$ .

# DATA

---

## Part A: Inelastic Collision

$$m_1(\text{g}) = \underline{\hspace{2cm}}$$

$$m_2(\text{g}) = \underline{\hspace{2cm}}$$

$$\frac{m_1}{m_1+m_2} = \underline{\hspace{2cm}}$$

$$L(\text{m}) = \underline{\hspace{2cm}}$$

$i$	$T_{1i}(\text{s})$	$T_f(\text{s})$
1		
2		
3		
4		
5		

## Part B: Elastic Collision

$$m_1(\text{g}) = \underline{\hspace{2cm}}$$

$$m_2(\text{g}) = \underline{\hspace{2cm}}$$

$$\frac{m_1}{m_2} = \underline{\hspace{2cm}}$$

$$L_1(\text{m}) = \underline{\hspace{2cm}}$$

$$L_2(\text{m}) = \underline{\hspace{2cm}}$$

$i$	$T_{1i}(\text{s})$	$T_{2i}(\text{s})$	$T_{1f}(\text{s})$	$T_{2f}(\text{s})$
1				
2				
3				
4				
5				

## CALCULATION AND ANALYSIS

---

1. For inelastic collisions, calculate the values of  $v_{1i}$  and  $v_f$  by dividing the length of the flag  $L$  by the time it took for the flag to pass through the photo-gate,  $T_{1i}$  and  $T_f$ , and then calculate  $\frac{|v_f|}{|v_{1i}|}$  for all five of your trials.
2. Calculate the average (mean) of the five values  $\frac{|v_f|}{|v_{1i}|}$ , the deviation of each value, the uncertainty of the average (mean), and the percent uncertainty for the average (mean) using equations 0.1, 0.3, 0.6 and 0.7.
3. Compare your average value of  $\frac{|v_f|}{|v_{1i}|}$  with the accepted value of  $\frac{m_1}{(m_1+m_2)}$ . Calculate the percent error of your calculation using equation 0.2. Is the % error less than or greater than the % uncertainty? Does the experimental evidence support the conservation of momentum?
4. For ONE of your collisions, calculate the kinetic energy of  $m_1$  before the collision and the kinetic energy of  $m_1+m_2$  after the collision. Calculate the percentage of the initial kinetic energy lost in the collision, as shown in equation 4.9.
5. For each of the five elastic collisions studied, calculate the values of  $v_{1b}$ ,  $v_{1f}$ ,  $v_{2b}$ , and  $v_{2f}$  by dividing the length of the flags  $L_1$  and  $L_2$  by the time it took for the flag to pass through the photo-gate,  $T_{1b}$ ,  $T_{2b}$ ,  $T_{1f}$ , and  $T_{2f}$ . Then calculate the value of  $\frac{|v_{2f}|+|v_{2i}|}{|v_{1i}|+|v_{1f}|}$  for all five of your trials.
6. Calculate the average (mean) of your five values of  $\frac{|v_{2f}|+|v_{2i}|}{|v_{1i}|+|v_{1f}|}$ , the deviation of each value, the uncertainty of the average (mean), and the percent uncertainty for the average (mean).
7. Compare your average value of  $\frac{|v_{2f}|+|v_{2i}|}{|v_{1i}|+|v_{1f}|}$  with the accepted value  $\frac{m_1}{m_2}$ . Calculate the percent error of your calculation using equation 0.2. Is the % error less than or greater than the % uncertainty? Does the experimental evidence support the conservation of momentum?
8. For ONE of your collisions, calculate the kinetic energy of the two masses before and after the collision, using the definition of the kinetic energy. Calculate the percentage of the initial kinetic energy lost in the collision, as shown in equation 4.9.
9. How does this compare with what happened in the inelastic collision?

# Experiment 5: Rotational Equilibrium

## OBJECTIVES

---

When the forces acting on an object do not make the object rotate, the object is in a state of rotational equilibrium. In this experiment you arrange forces that put an object into rotational equilibrium. You measure the vector quantities of these forces, calculate the torques exerted by these forces, and calculate the net torque acting on the object. The objectives of this experiment are as follows:

1. To measure the forces on an object in rotational equilibrium
2. To calculate the torques exerted by these forces
3. To test the hypothesis that an object in rotational equilibrium has no net torque acting on it

## THEORY

---

An object is rigid if its shape remains unchanged when forces are applied. A rigid object is in translational equilibrium when it has no linear acceleration. This was studied in Experiment 2. A rigid object is in rotational equilibrium when it has no angular acceleration. Therefore, to be in equilibrium, two conditions must be satisfied.

1. As described by Newton's second law, the vector sum of the forces acting on the object and labeled by the index  $i$  must be zero, as shown in equation 5.1.

$$\text{Translational Equilibrium} \quad F_{total} = \sum_i F_i = 0 \quad (5.1)$$

If all the forces  $F_i$  are applied in a plane, then one can project the forces on the x and z axes as shown in equation 5.2.

$$\begin{aligned} \text{2-D Translational Equilibrium} \quad F_{total,x} &= \sum_i F_{i,x} = 0 \\ F_{total,z} &= \sum_i F_{i,z} = 0 \end{aligned} \quad (5.2)$$

Here the x-axis is horizontal and the z-axis is vertical.

2. The sum of the torques acting on the object and labeled by the index  $i$  must be zero, as shown in equation 5.3.

$$\text{Rotational Equilibrium} \quad \tau_{total} = \sum_i \tau_i = 0 \quad (5.3)$$

Here the torque due to the force  $F_i$  about a pivot point  $O$  is defined by

$$\text{Torque} \quad \tau_{i,O} = F_{i,\perp} r_i \quad (5.4)$$

In this formula  $r_i$  is the length of the lever arm, defined as the distance between the pivot point  $O$  and the application point  $A_i$  of the  $i$ th force, and  $F_{i,\perp}$  is the component of  $F_i$  perpendicular to the vector  $r_i$ . This is illustrated in figure 5.1. The torque condition is true for every pivot point  $O$ . Since the choice of pivot point is arbitrary, you can use one that is convenient for calculation.

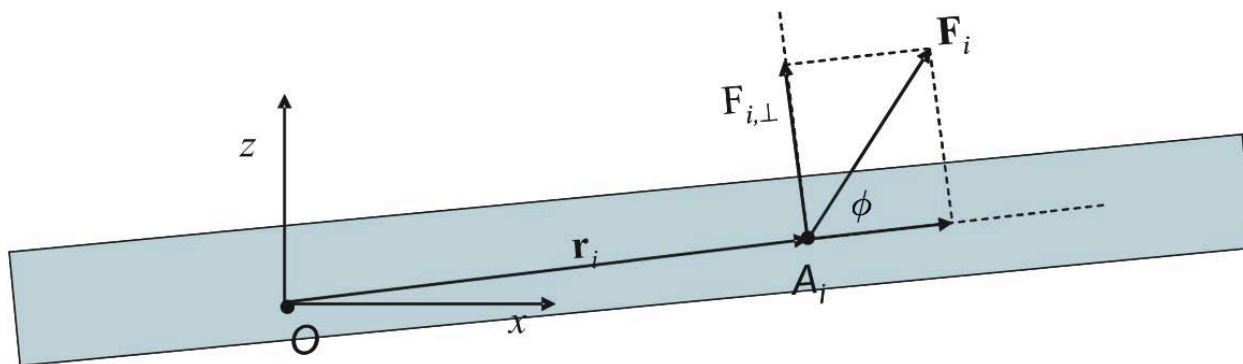

**Figure 5.1** The torque due to a force  $\vec{F}_i$  about a pivot point  $O$

If the force tends to rotate the object counterclockwise the torque is considered positive. If the force tends to rotate the object clockwise the torque is considered negative. If  $\phi$  is the angle between the force vector  $\vec{F}_i$  and lever arm, then the component of the force in the direction perpendicular to  $r_i$  is given by equation 5.5.

$$\text{Perpendicular force} \quad F_{i,\perp} = |\vec{F}_i| \sin \phi \quad (5.5)$$

The center of gravity of an object is the point, inside or outside the object, where the net force of gravity on all the particles of which the object is composed acts. Since one of the forces always acting on an object is gravity, you must measure the mass of an object and the location of its center of gravity in order to verify the equilibrium conditions above.

### ACCEPTED VALUES

As in Experiment 2, the accepted value for the sum of the torques on an object in equilibrium is 0. A useful way to characterize the accuracy of our measurement is to divide the magnitude of the net torque by the sum of the magnitudes of the individual torques multiplied by 100%, as shown in equation 5.6.

$$\% \text{ Discrepancy} = \frac{|\tau_{total}|}{\sum_i |\tau_i|} \times 100\% \quad (5.6)$$

In the numerator you add all the torques first, then take the absolute value. In the denominator you take the absolute values first, then add.

### APPARATUS

- A rigid object
- 2 spring balances (0-2000 g)
- assortment of weights (hook type)
- knife edge
- balance

The rigid object used in this experiment consists of a metal bar with four pivoted hooks mounted along the bar, two on each side, with protractors to indicate the angles the forces on the hook make with the major axis of the bar as shown in figure 5.2. We choose the pivot point  $O$  to be on the left end of the bar.

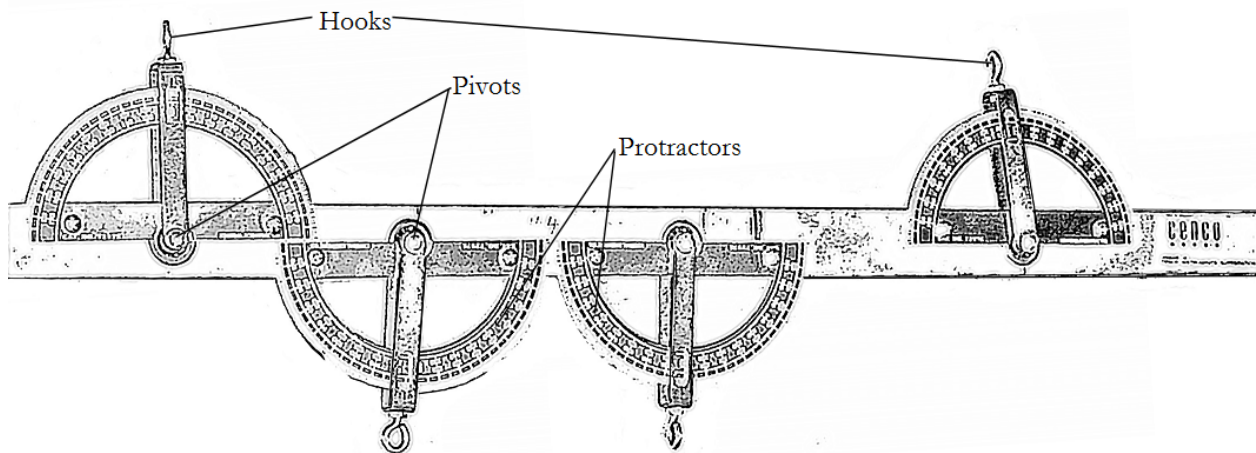

**Figure 5.2** The components of the rigid bar with protractors to measure force angles

## PROCEDURE

1. Balance the rigid object over a knife edge and measure the distance from the left end of the object to the knife edge. Record the result as the length lever arm  $r_0$ .
2. Weigh the rigid object using your balance and record the result as the mass of the rigid object  $m_0$  in the data table.
3. Check each spring balance with nothing attached. If they do not read zero, turn the adjustment screws until the spring balances all read zero.
4. Support the rigid object by the two spring balances so that each balance pulls vertically on one of the two pivoted hooks nearest the ends of the bar as shown in figure 5.3. Record the forces acting on the rigid object in the data sheet for Part A. Measure the distances from the left end which enables you to calculate the lever arms and thus the torques.

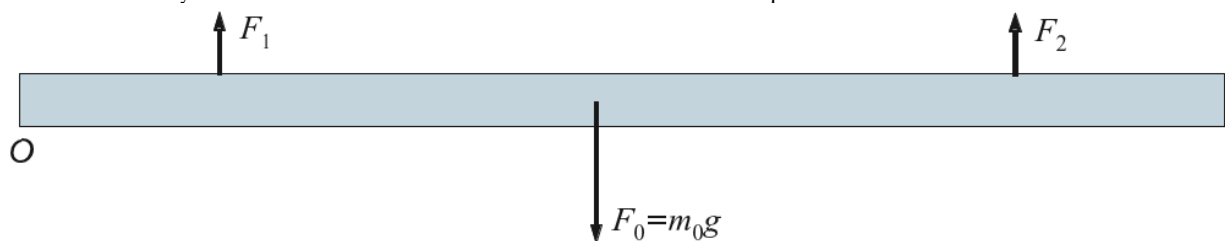

**Figure 5.3** The force vectors for Part A which tests the gravitational force only

5. Support the rigid object as in step 4 and add weights to the other two pivoted hooks so that all the external forces acting are vertical and the bar horizontal as shown in figure 5.4. Attach masses that exceed 400 g with one sufficiently different from the other so that the spring balance readings differ by at least 300 g. Record all forces and distances in the data sheet for Part B.



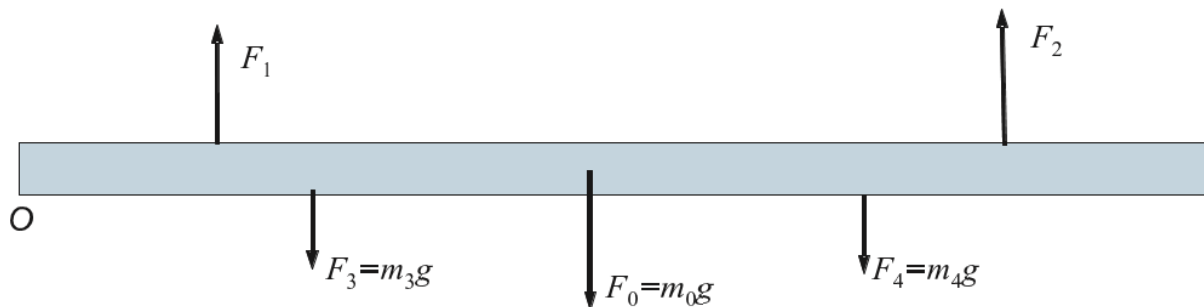

**Figure 5.4** The force vectors for Part B which tests two vertically hanging weights

- Repeat step 5 with the two upward forces pointing outward as shown in figure 5.5. Again, both hanging masses should differ by at least 300 g. Record angles between the upward forces and the bar, all forces, and all distances in the data sheet for Part C.

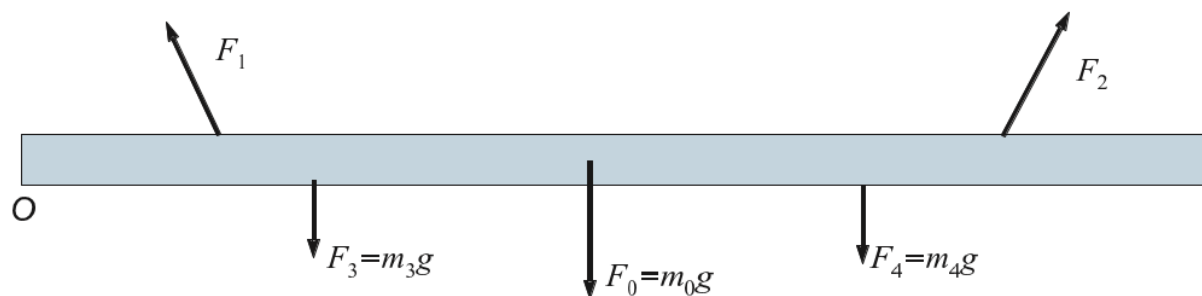

**Figure 5.5** The force vectors for Experiment 3 which tests two angled upward forces

## DATA

$m_0(\text{g}) =$  \_\_\_\_\_

### Part A

$i$	$m_i$ (g)	$F_i$ (N)	$\phi_i$ ( $^\circ$ )	$r_i$ (cm)
0				
1				
2				

### Part B

$i$	$m_i$ (g)	$F_i$ (N)	$\phi_i$ ( $^\circ$ )	$r_i$ (cm)
0				
1				
2				
3				
4				

### Part C

$i$	$m_i$ (g)	$F_i$ (N)	$\phi_i$ ( $^\circ$ )	$r_i$ (cm)
0				
1				
2				
3				
4				

## CALCULATION AND ANALYSIS

---

1. Explain why the center of gravity of the object is located directly above the knife edge position found in procedure 1.
2. Calculate the sum of the torques on the rigid object for Parts A and B. Remember: counter-clockwise torques are positive and clockwise torques are negative.
3. Calculate the % discrepancies of the torques for Part A and B using equation 5.6.
4. Calculate the sum of the horizontal and vertical forces for Part C using equations 5.2.
5. Calculate the sum of the torques on the rigid object for Part C.
6. Calculate the % discrepancies of the torques for Part C using equation 5.6.
7. Would it be possible to achieve equilibrium with only one of the two upward forces vertical and the other at an angle to the vertical? Use a diagram as part of your answer.

# Experiment 6: Archimedes' Principle

## OBJECTIVES

---

Archimedes discovered that you can measure the volume of a geometrically irregular solid by measuring the displacement of a liquid in which the solid is completely submerged. When scientists quantified the force of buoyancy, they discovered that you can find the density of an irregular object by comparing the weight of the liquid displaced by a submerged object with the apparent loss in the weight of an object. In this experiment, you measure the displacement of liquids by submerged and floating objects and measure the buoyancy force of liquids on submerged objects. The objectives of this experiment are as follows:

1. To measure the liquid displaced by floating and submerged objects
2. To test Archimedes' law
3. To calculate the density of liquids, solid objects that sink, and solid objects that float

## THEORY

---

Archimedes' law states that an object immersed in a liquid is buoyed up by a force equal to the weight of the liquid displaced by the object as shown in equation 6.1.

$$\text{Archimedes' Law} \quad F_b = \rho_L V g \quad (6.1)$$

Here  $\rho_L$  is the density of the liquid and  $V$  is the volume of the object, so that  $\rho_L V$  is the mass of the displaced liquid. This law can measure the density of an irregular solid object  $\rho_{obj}$  if the density of the liquid  $\rho_L$  is known. Weigh the object in the standard way (without the liquid) determining its weight as a function of density as shown in equation 6.2.

$$\text{Weight (standard)} \quad W = mg = \rho_{obj} V g \quad (6.2)$$

Then weigh the object while immersed in a liquid to determine its apparent weight as shown in equation 6.3.

$$\text{Apparent Weight (in liquid)} \quad W_{app} = W - F_b = (\rho_{obj} - \rho_L) V g \quad (6.3)$$

Dividing equation 6.3 by equation 6.2 eliminates  $V$ , which might be difficult to measure directly, and results in the relation shown in equation 6.4.

$$\text{Ratio of Apparent Weight to Standard Weight} \quad \frac{W_{app}}{W} = 1 - \frac{\rho_L}{\rho_{obj}} \quad (6.4)$$

Solving equation 6.4 for  $\rho_{obj}$  yields a formula for the density of the object, as shown in equation 6.5.

$$\text{Density of a solid} \quad \rho_{obj} = \rho_L \frac{W}{W - W_{app}} \quad (6.5)$$

Equation 6.5 can also calculate the density of the liquid, such as ethanol, once the density of the submerged object is known, as shown in equation 6.6.

$$\text{Density of a liquid} \quad \rho_L = \rho_{obj} \frac{W - W_{app}}{W} \quad (6.6)$$

In this experiment, you weight the object in two different liquids, water and ethanol, thus it is convenient to label the symbols by the indices W and E. Then equation 6.5 becomes

$$\text{Density of a solid, using water} \quad \rho_{obj} = \rho_W \frac{W}{W - W_{app,W}} \quad (6.7)$$

Substituting equation 6.7 in 6.6 gives a formula for the density of ethanol.

$$\text{Density of Ethanol} \quad \rho_E = \rho_W \frac{W - W_{app,E}}{W - W_{app,W}} \quad (6.8)$$

An object which floats in a liquid displaces a weight of the liquid equal to its own weight. If the object is elongated with length  $L$  and constant cross-sectional area  $S$ , its volume is  $V = LS$  and its mass is  $\rho_{obj}V$ . If the object is floating in a vertical position and the length of its submerged part is  $L_{sub}$ , the volume of the displaced liquid is  $V_{sub} = L_{sub}S$  and the mass of displaced liquid is  $\rho_L V_{sub}$ . So for a floating object  $\rho_{obj}V = \rho_L V_{sub}$  which algebraically yields equation 6.10.

$$\text{Density of a solid, floating} \quad \rho_{obj} = \rho_L \frac{L_{sub}}{L} \quad (6.10)$$

In the equations above, it is convenient to measure all the weights in grams instead of Newtons because the acceleration of gravity  $g$  cancels in all cases.

## ACCEPTED VALUES

The accepted value when testing Archimedes' Law in Part A is the weight of the water displaced by the submerged solid object.

The accepted values for the density of the liquids and solids analyzed in this lab at 20°C and in an atmosphere of 1 bar of pressure are as follows:

- Water:  $\rho_L = 998.21 \text{ kg/m}^3$
- Ethanol:  $\rho_L = 789.3 \text{ kg/m}^3$
- Aluminum:  $\rho_{obj} = 2698.9 \text{ kg/m}^3$

## APPARATUS

---

- |   |                |                                     |
|---|----------------|-------------------------------------|
| • metal object  | • overflow can | • thread (attached to metal object) |
| • platform balance (supported above the table by a stand) | • metal can    | • meter stick                       |
|   | • ethanol      | • graduated cylinder                |
|   | • wooden dowel | • beaker                            |

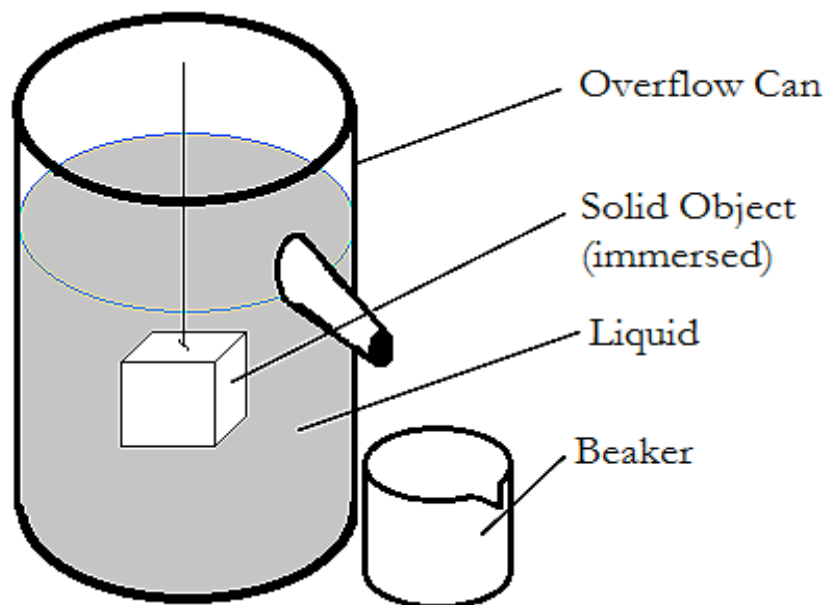

Figure 6.1 An overflow can directs displaced liquid into a beaker

## PROCEDURE

Table 6.1 is for steps 1-5 (for the metal object), while Table 6.2 is for steps 6-10 (for the wooden block)

1. Hang the object from the hook under the left pan of the balance using the thread. Measure the object's weight and record the result as the object weight,  $W$  (g) on Table 6.1.
2. Arrange the overflow can and the beaker so that water can flow from the spout of the overflow can into the beaker. Pour water into the can until it overflows. When the water has stopped dripping from the spout, weigh the beaker with the water in it and record the result as the initial weight of the beaker,  $W_{b,i}$  (g).
3. Place the beaker and its contents back under the spout. While keeping the object hung from the balance, lower the object by a thread into the water in the overflow can until it is completely immersed. When all the water displaced by the object has flowed into the beaker, weigh the beaker with the water in it and record the result as the final weight of the beaker,  $W_{b,f}$  (g)
4. Adjust the apparatus so that the object isn't touching the sides or bottom of the overflow can. Measure the apparent weight of the object when immersed in water and record the result on Table 6.1 under  $W_{app,W}$  (g).
5. Set the overflow can aside and dry the object. **Under the instructor's supervision**, fill the metal can with ethanol. Measure the apparent weight of the object when completely immersed in ethanol,  $W_{app,E}$  and record your result under  $W_{app,E}$  (g). **Under the instructor's supervision** (once again), pour the ethanol back into the ethanol bottle and close the bottle.
6. Measure the length of the wood block and record the result on Table 6.2 as the total length of the block,  $L_{total}$  (cm) .
7. Measure and record the width  $W$  (cm) and the height  $H$  (cm) of the wood block.
8. Measure and record the mass  $m$  (g) of the wood block.
9. Fill the graduated cylinder approximately to the halfway mark with water. Lower the wooden dowel into the water in the graduated cylinder until it floats.
10. Measure the length of the wood that is below the level of the water and record the result as the submerged length  $L_{sub}$  (cm). Dispose of any remaining water to end the experiment.

## DATA

---

### Part A: Testing Archimedes' Law

$W$ (g)	$W_{app,W}$ (g)	$W_{b,i}$ (g)	$W_{b,f}$ (g)

### Part B: Calculating the density of a solid object and ethanol

$W$ (g)	$W_{app,W}$ (g)	$W_{app,E}$ (g)

### Part C: Calculating the density of a floating object

$L_{total}$ (cm)	$W$ (cm)	$H$ (cm)	$m$ (g)	$L_{sub}$ (cm)

## CALCULATION AND ANALYSIS

---

1. Calculate the weight of the water displaced by the immersed object,  $W_{b,f} - W_{b,i}$  using the data from Part A.
2. Calculate the apparent loss of weight of the object when completely immersed in water,  $W - W_{app,W}$ , using the data from Part A.
3. Archimedes' Law predicts that the weight of the displaced water equals the apparent loss of weight of the object. Do your results support Archimedes' Law?
4. Calculate the density of the object  $\rho_{obj}$  using equation 8.7 and the data from Part B.
5. Calculate the % error in your result for  $\rho_{obj}$ .
6. Calculate the density of the ethanol  $\rho_E$  using equation 8.8 and the data from Part B.
7. Calculate the % error in your result for  $\rho_E$ .
8. Calculate the density of the wood block  $\rho_{wood, float}$  using equation 8.10 and the data from Part C.
9. Calculate the volume of the wood block using your data from Part C. (Remember volume = length  $\times$  width  $\times$  height.)
10. Calculate the density of the wood block  $\rho_{wood, actual} = \frac{m}{volume}$  using your data from Part C.
11. Using  $\rho_{wood, actual}$  as the accepted value, calculate the % error in your result for  $\rho_{wood, float}$ .

# Experiment 7: Simple Harmonic Motion

## OBJECTIVES

---

Simple harmonic motion is the motion of an object that is subject to a force that is proportional to the object's displacement. An object attached to a spring undergoes simple harmonic motion. The quantitative relationship between the spring force and the displacement is known as Hooke's Law. In this experiment, you observe the oscillation of an object attached to a spring to test Hooke's law and calculate the spring constant for the spring. The objectives of this experiment are as follows:

1. To measure the period of oscillation of a mass-spring system
2. To test Hooke's law with a spring
3. To calculate the spring constant for a spring

## THEORY

---

When a body is suspended from a spring, its weight causes the spring to elongate. The system is said to be in equilibrium when the object has a net acceleration of zero. The mass is suspended in its equilibrium position, as the force it exerts on the spring (its weight,  $F_G$ ) is equal to the force exerted by the spring ( $F_{spring}$ ) on the mass. The force exerted by the spring is what is often called Hooke's law and it varies with its change in length:

$$F_{spring} = -k \Delta x \quad (7.1)$$

where  $k$  is the spring constant, or the "stiffness" of the spring, measured in N/m, and  $\Delta x$  (m) is the resultant extension (or compression) of the spring.

When the hanging mass is slightly displaced from its equilibrium position, the system oscillates (moves back and forth, repeatedly) around that position with a period that is only dependent on the magnitude of the mass and the spring constant. This periodic motion is what is known as simple harmonic motion\*. The period  $T$  can be calculated using the equation below:

$$T = 2\pi \sqrt{\frac{m}{k}} \quad (7.2)$$

Thus, a plot of  $T^2$  vs.  $m$  for a given spring should be a straight line with a slope of  $4\pi^2/k$ .

## ACCEPTED VALUES

---

The accepted value for the spring constant is determined in Part A of the *Procedure*, where the extension of the spring is measured when known masses (easily converted into weights using  $F_G = mg$ ) are suspended from it. By equating the spring force to the hanging weight at object at equilibrium, we obtain:

$$F_G = k \Delta x \quad (7.4)$$

Thus, a plot of  $F_G$  vs  $\Delta x$  for a given spring should be a straight line with a slope of  $k$ .

## APPARATUS

---

- Hooke's Law apparatus
- half meter stick
- computer with Pasco interface
- 'slotted weights
- platform balance
- stopwatch

\* *A few specific conditions are necessary for motion to be considered "simple harmonic". See Giancoli (7th ed) pg # 293.*

The spring is equipped with a distance scale, as shown in Figure 7.1, so that you can see the equilibrium point change as you change the weight of the object. The scale and pointer should be removed for Part B of the experiment.

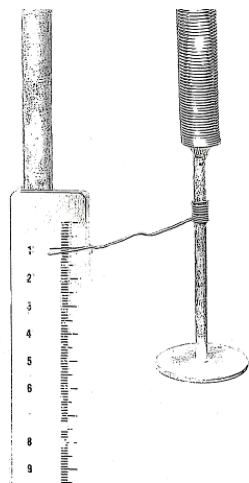

**Figure 7.1** Detail of the spring and scale of the Hooke's law apparatus (Part A)

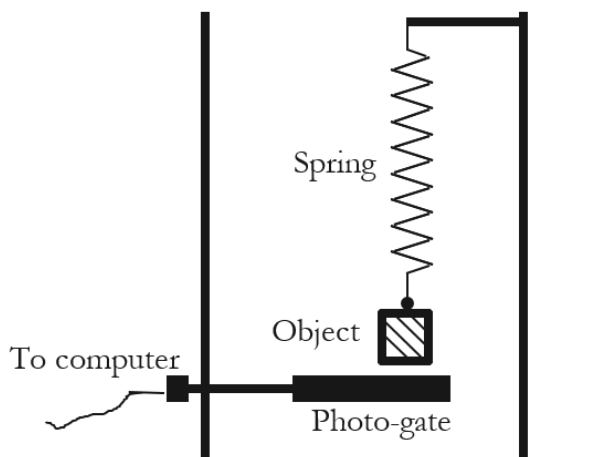

**Figure 7.2** Photo-gate positioned to measure the motion of the object (Part B)

The computer interface measures motion through a photo-gate (aka light gate). The Hooke's law apparatus hangs the object (weights) at the end of a spring, which cuts across the light path in the photo-gate on every downward swing, if positioned as shown above in Figure 7.2.

## PROCEDURE

### PART A

1. Adjust the pointer so that it is directing to readings on the scale of the Hooke's law apparatus. Record the initial value,  $x_0$  (cm)
2. Add a 25 g weight to the hanger and record the new position of the pointer as the displaced equilibrium position  $x$  (cm) .
3. Repeat step #2 (above) until Table 7.1 is completed, by adding 25 g and recording the new equilibrium position for every increment in mass.

### PART B

1. From the desktop choose the "Simple Harmonic Motion" icon.
2. Position the photo-gate so that it is just below the bottom of the mass. Start the system oscillating by gently pulling down on the mass and releasing it. Adjust the position of the photo-gate so that when the system is oscillating, the bottom of the mass interrupts the photo-gate but does not pass completely through the gate. This way the bottom of the mass starts the timer and, when it completes one oscillation, stops the timer.
3. Stop the system oscillating and swing the photo-gate out of the way so that it does not interrupt the oscillating mass. Start the oscillations by gently pulling down on the mass and releasing it vertically. When the system is oscillating smoothly, with little sideways drift, swing the photo-gate in place under the spring so that the weights intercept the path of light every time the spring moves down to its lowest point.
4. Choose "Play" on the computer interface to start the computer collecting data. Choose "Stop" when the data table is completed on the monitor. Record the average period displayed at the bottom of the table in the data table for Part B.



## PART B (alternative)

1. *If you're using a stopwatch:* start the system oscillating by gently pulling down on the mass and releasing it. When the system is oscillating smoothly use a stopwatch to time 10 periods of oscillation. Divide the time you measure by 10 and record it in the data table for Part B.
2. Repeat steps 8 through 10 if you're using a computer, or step 11 if you're using a stopwatch, with masses of 125 g, 150 g, 175 g and 200 g. Increase the mass by sliding the appropriate slotted masses on top of the 100 g hanging weight. For the 200 g trial you can use the 200 g hanging weight.
3. With a 200 g hanging weight, observe the oscillations for some time as the amplitude slowly decreases. Do you notice any change in the period, or does the period stay roughly constant? Record your observation on the data sheet.

## CALCULATION AND ANALYSIS

---

1. Calculate the gravitational force  $F_G$  due to each of the masses in the data table in Part A, using the formula  $F_G = mg$ .
2. Draw a graph of the force  $F_G$  (N) vs extension  $\Delta x$  (m).
3. Calculate  $k$  graphically by taking the slope of the graph using equation 0.9.
4. Draw a graph of the period squared  $T^2$  versus the moving mass  $M$  using the data from Part B.
5. Find the slope of the graph using equation 0.9.
6. Calculate the % error of  $k$  calculated from Part B using  $k$  calculated from Part A as the accepted value.
7. As the spring oscillates while you measure its period, the amplitude of the oscillation decreases. Do you see any evidence that the period of oscillation changes as the amplitude decreases? In other words, does the period depend on the amplitude (or vice versa)?

## DATA

---

**Table 7.1: Equilibrium point**

<b>Added mass (g)</b>	<b><math>x_0</math> (cm)</b>
0.0	0.00
25.0	
50.0	
75.0	
100.0	
125.0	
150.0	
175.0	
200.0	

**Table 7.2: Oscillation data**

<b>Mas (g)</b>	<b>Average <math>T</math> (s)</b>
100.0	
125.0	
150.0	
175.0	
200.0	